



INTERNATIONAL ROADMAP FOR DEVICES AND SYSTEMS™

INTERNATIONAL
ROADMAP
FOR
DEVICES AND SYSTEMS™

2023 UPDATE

OUTSIDE SYSTEM CONNECTIVITY

THE IRDS IS DEvised AND INTENDED FOR TECHNOLOGY ASSESSMENT ONLY AND IS WITHOUT REGARD TO ANY COMMERCIAL CONSIDERATIONS PERTAINING TO INDIVIDUAL PRODUCTS OR EQUIPMENT.

© 2023 IEEE. Personal use of this material is permitted. Permission from IEEE must be obtained for all other uses, in any current or future media, including reprinting/republishing this material for advertising or promotional purposes, creating new collective works, for resale or redistribution to servers or lists, or reuse of any copyrighted component of this work in other works.

Bluetooth® SIG and its members, licensors, and suppliers own all right, title, and interest (including intellectual property rights) in the Services, Content, and all draft and adopted specifications for the Bluetooth standard and reserve all rights not expressly granted to you in these Terms or, if applicable, the SIG Member Terms. The Bluetooth logos and word marks referenced in the Services and Content are the trademarks of Bluetooth SIG and its affiliates. Any other company names, product names, service names and logos referenced in connection with the Services or Content may be the trademarks of their respective owners.

Wi-Fi® and Wi-Fi Alliance® are registered trademarks of Wi-Fi Alliance.

The IEEE emblem is a trademark owned by the IEEE.

"IEEE", the IEEE logo, and other IEEE logos and titles (IRDS™, IEEE 802.11™, IEEE P1785™, IEEE P287™, IEEE P1770™, IEEE P149™, IEEE 1720™, etc.) are registered trademarks or service marks of The Institute of Electrical and Electronics Engineers, Incorporated. All other products, company names or other marks appearing on these sites are the trademarks of their respective owners. Nothing contained in these sites should be construed as granting, by implication, estoppel, or otherwise, any license or right to use any trademark displayed on these sites without prior written permission of IEEE or other trademark owners.

Table of Contents

Acknowledgments	vi
1. Introduction	1
1.1. Current State of Technology	2
1.2. Drivers and Technology Targets	2
1.3. Vision of Future Technology	3
2. Scope of Report	3
2.1. IoE Communication	3
3. Summary and Key Points	4
4. Challenges	5
4.1. Near-term Challenges	5
4.2. Long-term Challenges	5
5. Technology Requirements	7
5.1. Summary	7
5.2. Data Center	8
5.3. High Performance Computing	13
5.4. Quantum Computing and Communication	13
5.5. Telecommunication	14
5.6. Last Km or Mile Communication	15
5.7. Office and Factory Local Area Networks	16
5.8. Mobile Smart Phones	17
5.9. Automobiles	19
5.10. Aerospace	21
5.11. Medical and Health Devices	22
5.12. Miscellaneous IoT Devices	23
6. Integrated Circuit and Devices	24
6.1. RF Integrated Circuits and Devices	24
6.2. Photonic Integrated Circuits and Devices	33
6.3. Optical Test	37
7. Cross Teams	37
7.1. Systems and Architecture	37
7.2. More Moore	38
7.3. Beyond CMOS	38
7.4. Packaging	38
7.5. Environmental Safety, Health and Sustainability	38
8. Emerging/Disruptive Concepts and Technologies	39
8.1. mmWave Communication	39
8.2. Integrated Silicon Photonics	39
8.3. Photonic Switching and Routing	39
8.4. Emerging Phenomenon to Enable New Photonic Control	39
8.5. Structured light for communications	40
9. Conclusions and Recommendations	40
9.1. Optical Interconnect Conclusions	40
9.2. Optical Interconnect Recommendations	40
9.3. RF Wireless Conclusions	41
9.4. RF Wireless Recommendations	41
10. Acronyms and Abbreviations	42
11. References	49

List of Figures

Figure OSC-1	Wireless and Optical Interconnect Networks Example	2
Figure OSC-2	a. Active Optical Cable (AOC), here with multimode fiber, and b. AOC Connected to Back of Server Rack in Data Center	9
Figure OSC-3	Potential Integration of Advanced Optical Interconnect Technologies Over Time.....	11
Figure OSC-4	Evolution of Optical Interconnects to Shorter Distances Depends on Cost, Data Density, and Added Latency of Electrical-Optical-Electrical Conversions.....	12
Figure OSC-5	Potential Path for FTTX Extending Further from the Telecom Office to Businesses and Homes.....	15
Figure OSC-6	ADC Performance Survey	18
Figure OSC-7	Power Amplifier Output Power	19
Figure OSC-8	Automobiles Have Multiple Networks to Measure Performance, Detect Obstacles, Control Operation, Deliver Entertainment to the Passengers, and Provide Communication to the “Cloud”.....	20
Figure OSC-9	Optical Interconnects Can Provide Interconnects for Internet Connectivity and Multi-Media Entertainment Distribution and in the Future Flight Deck with Computing Resources, Switches and Actuators, and Sensors in the Aircraft	22
Figure OSC-10	Example of Wireless Flying Network Hub that Would Provide Internet Connectivity to Metropolitan or Rural Areas	22
Figure OSC-11	Range of Select LPWAN Systems vs. Their Maximum Data Rates	23
Figure OSC-12	CMOS Roadmap for Peak f_T vs. Physical Gate Length for FDSOI and Double- gate (FinFET) MOSFETs Based on Technology CAD	25
Figure OSC-13	CMOS Roadmap for Transconductance per Unit Gate Width, g_m , vs. Physical Gate Length for FDSOI and Double-gate (FinFET) MOSFETs Based on Technology CAD	25
Figure OSC-14	High Speed SiGe HBT f_T and f_{MAX} Roadmap vs. Year of Production.....	26
Figure OSC-15	High Speed SiGe HBT Maximum Gain Roadmap vs. Year of Production	27
Figure OSC-16	HBT Minimum Noise Figure with Ideal Reactive Components vs. Year of Production	27
Figure OSC-17	High-Speed SiGe BiCMOS Potential Solutions.....	28
Figure OSC-18	III-V Roadmap for f_T	29
Figure OSC-19	III-V Roadmap for f_{MAX}	30
Figure OSC-20	III-V Roadmap for Associated Gain.....	30
Figure OSC-21	III-V Minimum Noise Figure Roadmap	31
Figure OSC-22	Group III-V Compound Semiconductors Potential Solutions.....	32

List of Tables

Table OSC-1	Technologies Mapped to Applications	3
Table OSC-2	Optical Interconnect Building Blocks	4
Table OSC-3	Difficult Challenges	6
Table OSC-4	Wavelength Division Multiplexing Module Performance Requirements	9
Table OSC-5	Data Center Outside of Rack Requirements and Potential Solutions	9
Table OSC-6	Data Center Inside of Rack Requirements and Potential Solutions	12
Table OSC-7	Telecommunications Optical Interconnect Requirements	15
Table OSC-8	Fiber to X (FTTX) Requirements and Potential Solutions	15
Table OSC-9	Office and Factory LAN Requirements and Potential Solutions	16
Table OSC-10	Free Space Optical Communication - Key Attribute Needs	16
Table OSC-11	Mobile Device Wireless Performance Requirements	17
Table OSC-12	Autonomous Vehicle Sensor Communication Data Rates	19
Table OSC-13	Automotive Optical Interconnect Requirements	21
Table OSC-14	Aerospace Optical Interconnect Requirements (Preliminary)	22
Table OSC-15	IoT Wireless Performance Requirements (Battery)	24
Table OSC-16	RF and Analog Mixed-Signal Bipolar Technology Requirements	26
Table OSC-17	Group III-V Compound Semiconductor FET and Bipolar Transistors Technology Requirements	31
Table OSC-18	Optical Interconnect Test Capability Requirements	37

Acknowledgments

Takeru Amano, Sevedi Ashkan, Carlos Augusto, Didier Belot, Frederic Boeuf, Bill Bottoms, Sylvain Bourdel, Kirk M. Bresniker, Jennifer Dionne, C. Michael Garner, Yoshihiro Hayashi, Yuzo Ishii, Hiroki Ishikuro, Ajey Jacob, Mark Lawrence, Kevin Leigh, Di Liang, Robert L. Lingle, Tomohiro Matsumoto, Sven Mattson, Hiroki Morimura, Nobuhiko Nakano, Dick Otte, Earl Parsons, Chuck Richardson, Francois Rivet, Michael Schroeter, Ashkan Seyedi, Sudharsanan Srinivasan, Lars Sundstrom, Alexei Tchelnokov, Koichi Tokudome, Leif R. Wilhelmsson, and James Young.

OUTSIDE SYSTEM CONNECTIVITY

1. INTRODUCTION

The Internet of Everything (IoE) is continuing to expand in applications that demand higher volumes of higher performance communication. The IoE was initially defined as a wide range of Internet of Things (IoT) devices communicating with cloud computing that store data and which was analyzed with applications and actions communicated. As IoE was used for a broader range of applications, some applications had unacceptably slow performance due to the latency of communicating with the cloud. To overcome this latency limitation, some applications added local storage and processing close to the IoT devices and network, which is referred to as fog computing.

Most applications will employ RF/microwave wireless communication to connect to the internet which will then connect through high-performance backhaul or fiber optical interconnects to a cloud data center. In the future, millimeter waves (mmWaves), massive multiple input multiple output (MIMO) or other 5G media will be implemented for high-speed connection to terminal devices, while low-power wide area network (LPWAN) communications, such as long-range WAN (LoRaWAN), SIGFOX, LTE Cat 0 and narrow band-IoT (NB-IoT), will be utilized to connect and provide enormous data to the cloud and/or fog computing system from IoT-edge sensor devices. Within the data center, communication to servers is through fiber optical interconnects with signals being routed through multiple routers. Upon arrival at a router, the optical signals are converted to electrical, routed and then converted back to optical signals, which adds to energy consumption and latency. The requested data is then routed out of the data center and returned to the requesting IoT devices through a path similar to the request path.

Applications that required fast communication and decision making, such as autonomous vehicles and traffic control, are adopting fog computing. In this model fast communications are made between the fog and vehicles and traffic flow controls and filtered data is communicated between the fog computing and the supporting cloud computing capabilities. Fast communication with low latency is required between the IoT devices and the fog, while fast communication will be required also between elements of the fog. Computing in the fog can be performed in a micro data center, which is connected to the network and the internet.

With the rapid growth of high data rate internet applications and IoT, communication rates in data centers need to grow to support high speed access and provide high speed low latency communication between servers and memory or other servers. With increased use of high-resolution video, virtual reality, and augmented reality applications, ever higher data rate communication with lower latency is required in data centers. Communication between racks and switches is carried by optical interconnects; however, the capacity of switches is increasing faster than the capacity of fiber interconnects. Also, the power consumed by the switches in data centers is ~approximately 30% of the power consumed in the data center. To reduce switching power and overcome the fiber capacity gap, companies are working to integrate silicon photonics into the switch. There are also efforts to extend fiber into the server into packages and thus reduce power. There are significant technical challenges with developing and implementing single mode fiber with low loss for these applications. These challenges will be discussed in this chapter.

High performance computing (HPC) is increasingly being used in machine learning applications. A critical requirement in machine learning is for high-speed simultaneous broadcast of data to many processors. So, new interconnect technology is needed and new silicon photonic devices may enable communication solutions.

Emerging information processing technologies based on superconductor circuits operate at cryogenic temperatures (below -150 C or 123.15 K) and have demanding requirements for connectivity between cryogenic and room temperature environments. Examples include single flux quantum (SFQ) digital logic, which produces voltage pulses on the order of 1 mV high and 1 ps wide, and some circuits used for quantum computing (QC). As cryogenic electronic technologies progress, efficient interconnects need to be developed to allow communication with room temperature systems at high data rates. For additional information and current status, see the IRDS chapter on Cryogenic Electronics and Quantum Information Processing.

2 Introduction

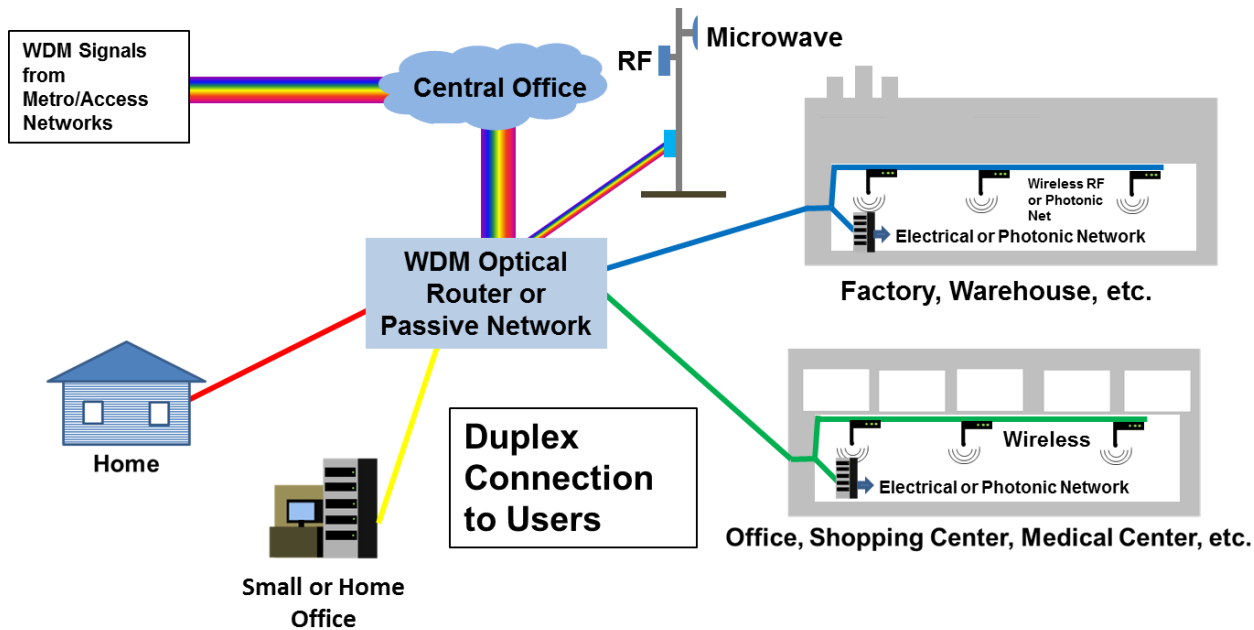

Figure OSC-1 Wireless and Optical Interconnect Networks Example

Note: An example of a network from the “cloud” to large offices, small offices and homes where electrical, optical and wireless communication are employed to support different needs.

1.1. CURRENT STATE OF TECHNOLOGY

Currently, mobile devices are supported by 4G LTE and 5G networks with download data rates of up to 5 gigabits per second (Gbps). IoT devices communicate over a wide range of networks including multiple LPWAN, Bluetooth, Wi-Fi, and higher data rate devices over cellular 5G networks. The IoT devices communicating to Bluetooth and LPWAN networks typically communicate at data rates less than 2 Mbps, or less than ~100 kbps in LoWA. Many of the IoT sensors and transducers operate on battery power, so they send data in burst and go into standby mode when not transmitting data. Some IoT devices such as wireless headphones must receive data continuously while operating.

Telecommunication fiber optic networks are currently able to communicate at 100 terabits per second (Tbps) utilizing multiple wavelengths and modulation technologies. Microwave backhaul communication currently operates at data rates of 400 Mbps. Thus, wireless backhaul is easier to install; however, fiber backhaul can carry a much higher rate of data communication.

Within the data centers, most are using fiber optic active optical cables (AOC) that take electrical data input, convert it to optical data with lasers, transmit it over fiber and then convert it to electrical output at the other end of the cable. Current AOC communicate at 400 Gbps; however, once a data center is “wired” with AOC, the maximum data rate is limited by the cabling. To connect every server in a data center, this requires a server to communicate with a switch(router) and within a large data center, data must go through approximately 6–8 switches before reaching its destination.

The use of application specific processors in Data Centers has increased in recent years and these may have unique communication requirements. These include matrix solvers, neural processors, and in the future quantum computers may be used in data centers.

1.2. DRIVERS AND TECHNOLOGY TARGETS

For mobile cellular devices, the drivers are the maximum data rate and the number of antennas to support multiple wireless technologies. The maximum data rate for cellular is currently 5Gbps and the number of antennas is 13 to support GPS, Bluetooth, Wi-Fi, 3G, and 4G LTE and other needs. Cellular data rates are targeted to increase to 7 Gbps in 2023 with the introduction of improved 5G wireless technology. Power amplifiers and A/D converters need to have improved energy efficiency at multi-GHz and mmWave frequencies to support 5G-6G to enable improved battery life for mobile phones at high data rates.

For data centers, the drivers for communication are the data rate per server unit, which is currently 400 Gbps, and power consumption. Data centers typically upgrade servers approximately every three years and would like to have the data rates increase when they upgrade the servers; however, this would require upgrading the AOCs with every server upgrade. Power consumed in communication and switching is becoming significant, 30% of data center power in 2013, so Data Centers are requesting that optical I/O be integrated into the switch package by the 51.2 Tbps switch. The Consortium for On Board Optics (COBO) is driving to have the photonic transmitter and receiver on the board and connecting this to single mode fiber in the data center. This would enable upgrading the data center communication data rate when the servers are upgraded. At the same time, the routers in data centers are adding communication capacity and ports that consume considerable power, so the industry is seeking ways to reduce router thermal density and improve energy efficiency.

Analysis of “big data” is a growing application and multiple computers need to be engaged and able to exchange raw and partially processed data with low latency. One type of analysis that is increasingly being employed is “machine learning” that often uses neural networks. Currently, data centers and high-performance computers (HPC) are used for machine learning with extremely large training sets where inter-processor communication bottlenecks slow the learning process. If machine to machine or machine to memory latency could be reduced to 250-300ns for a large number of processors, this could significantly improve machine learning. As a wider range of application specific processors are used in data centers with increased need for larger data sets, communication requirements will be more difficult to fulfill with the required latency.

1.3. VISION OF FUTURE TECHNOLOGY

Cellular communication devices will be able to automatically connect to data rate source with the required speed for the applications being used. Autonomous vehicles will be able to have continuously updated maps of traffic issues, obstacles and hazards as well as communicating with other vehicles to understand their intentions to change directions. Mobile IoT devices and systems will be able to connect to their host application on the cloud through a variety of networks without allowing security breaches of themselves, the host application or the internet or cloud.

Data centers will have high data rate communication that is upgraded when servers are upgraded without recabling the data center. Latency of communication within the data center will be reduced by all optical switching and routing; however, if latency could be dramatically reduced new data center architectures may be enabled. Power consumption of communication and routing will be reduced by a factor of 10 even though the data rate has increased by a factor of over 10.

Quantum computers (QC) have the potential to solve very difficult problems and may be employed as an application specific processor; however, they need to have much larger sets of Qbits. They must be able to communicate data with other quantum computers and other types of information processors. For cryogenic QC, the thermal load of interconnects in the cryo system must be low, so optical interconnects would be a good solution. This would enable integration of multiple QCs within a data center.

2. SCOPE OF REPORT

2.1. IOE COMMUNICATION

Outside System Connectivity encompasses the assessment of communication requirements and technology for products and devices on the Internet of Things (IoT) to communicate with the internet and technologies required to deliver information to the cloud and within the cloud. Applications include automobiles, aerospace, and a wide range of IoT applications including personal use, home, transportation, factory, and warehouse. Communication of data over fiber optic communication circuits to data centers and fiber optic communication within data centers is in the scope of this chapter.

With the wide range of applications that need to communicate on the Internet of Everything, the applications in OSC scope are mapped to the technologies that support them or may support them in the future in Table OSC-1.

Table OSC-1 [Technologies Mapped to Applications](#)

2.1.1. RF WIRELESS

Examples of IoT devices could include numerous products, embedded medical devices, appliances, autonomous vehicles, tools, energy monitoring devices, etc. Many of these devices will communicate with the internet through wireless RF and may need to connect through multiple types of systems, such as Wi-Fi, Bluetooth, LPWAN, wireless phone protocols, etc. For many devices such as implanted medical devices, autonomous vehicles, energy regulating devices, etc., security from

4 Summary and Key Points

tampering will be critical, so both software (not included) and hardware solutions may be required to provide adequate security from wireless intruders or internet hacking. RF wireless communication devices including analog to digital (A/D) and digital to analog (D/A) converters, amplifiers, mixers, passives, and antennas. To meet the frequency, power and functionality requirements of the D/A converters and amplifiers may require circuits based on CMOS, BiCMOS, SiGe, or III-V technologies. Heterogeneous 2,5D and 3D integrations of silicon-based and III-V technologies would facilitate the power efficiency tradeoff for mmWave RF, and wide band data conversion functions for 5G and beyond communications.

2.1.2.PHOTONIC INTERCONNECTS

Photonic interconnects are used for communication in local area networks (LANs), telecommunication networks to connect base stations to telecommunication centers and cloud data centers and communication within the data center. Free space optical communication is emerging as a potential application in warehouses to manage inventory as well as data centers to provide greater flexibility via software defined directional transmission and reception. Devices include signal conditioners, lasers, a variety of modulators, technologies to enable mixing wavelengths (MUX) and separating wavelengths (DeMUX) in compact spaces and detectors and amplifiers, signal conditioners, waveguides and photonic connectors. The scope also includes technologies to integrate optical devices on substrates such as silicon, in packages or on printed circuit boards to reduce size, increase operating speed, and reduce cost. In the longer term, devices that could enable hybrid or all photonic based switching and routing and photonic logic. A new potential application of photonic interconnects is for quantum computer I/O or to network multiple quantum computers into a larger virtual quantum computer. Components required for different optical interconnect types are shown in Table OSC2.

Table OSC-2 [Optical Interconnect Building Blocks](#)

3. SUMMARY AND KEY POINTS

RF wireless and photonic interconnect data rates need to increase to support high performance applications, large increase in IoT devices and storage and analysis of data on the cloud. The largest increase in data rate for RF wireless came with the introduction of 5G technology, which will be used for content rich applications on mobile phones and to analyze data from the huge number of sensors on autonomous vehicles. These high data rates (>1 Gbps) may also enable totally new applications. In data centers, the Consortium for On Board Optics (COBO) is working with research consortia and industry to enable board level photonics so data rates can be upgraded when new servers are installed in data centers, reduce power consumption, and reduce PCB weight. In addition, the data center industry is driving for the integration of optical I/O into switch packages to reduce switch power requirements for the 51.2 Tbps switches and beyond.

Multiple LPWANs, Bluetooth, Wi-Fi, and 5G+ are competing to provide access for IoT devices. Some applications need very low power operation, so more energy efficient devices may be needed for the radios.

Significant progress has been made to develop active phased array antennas to enable 5G+ communication. These highly directional antennas enable longer range communication with lower power, reduce interference and may enable methods to improve security.

In the past year, products have been introduced with silicon photonics that enable higher data rate communication with lower power and cost. These products can be integrated into AOCs or integrated onto boards for board level photonics. Future devices need to operate at higher data rates and have higher levels of integration in more compact form factors to reduce power consumption and cost.

For board level or package-integrated photonics to be viable in data centers, robust low loss (<1 dB) connectors must be developed for single mode fiber connection to the package or board.

4. CHALLENGES

4.1. NEAR-TERM CHALLENGES

4.1.1. RF NEAR-TERM CHALLENGES

In the near term, the key challenges for RF are achieving high-performance energy efficient RF analog technology compatible with CMOS processing and delivering capabilities to support emerging high data rate applications for fixed and mobile devices, as shown in Table OSC-3. Power amplifier and digital to analog and analog to digital converter efficiency degrade at higher frequencies and sampling rates, respectively. To achieve high performance RF with high energy efficiency, CMOS gate resistance must be reduced with technologies that are compatible with CMOS processing. Furthermore, SiGe and III-V performance needs increased f_T and f_{MAX} while being integrated with CMOS. Furthermore, passive devices need to be integrated on CMOS with higher performance.

To support a wide range of internet of everything (IoT) devices, increasingly complex antennas need to be developed that can fit in small form factor systems. Also, security capabilities need to be developed to eliminate hacking or eavesdropping by unauthorized devices.

With the density and data rates of RF communication continuing to increase, the potential for interference between transmitters will increase, so techniques will be needed to reduce interference. Massive MIMO (mMIMO) and mmWave will need very energy efficient components (i.e. power amplifiers, etc.) and highly directional antennas to broadcast longer distances with lower power consumption. Also, mobile devices such as phones will need multiple antennas to connect to base stations as the device changes directions and some paths may be obstructed by absorbing structures. With multiple antennas, multiple circuits will be needed to send signals to the antennas with correct phase and these need to be very energy efficient.

4.1.2. OPTICAL INTERCONNECT NEAR TERM CHALLENGES

Many applications would make use of optical interconnects to increase data rates and reduce energy consumption; however, significant challenges must be overcome for these to be viable. In the near term, it is critical that the cost of optical interconnect technologies be reduced and also that the information density be increased, as shown in Table OSC-3. The most immediate need to exploit optical technology for connectivity is to reduce cost for emerging applications. The known current and potential applications are:

1. Data rates through switches (routers) and I/O densities in data centers are doubling every 2-3 years and the I/O power will limit performance, so integration of the optical I/O into the switch package is needed to reduce power consumption.
2. Data transmission for <5 km fiber to the home, <1–2 km in data centers, <1–2 meter in racks, a few centimeters device to device.
3. High end microprocessors requiring >10 Tb/s of data IO.

Reducing the cost of optical technologies for these applications requires design, process development and component integration to minimize acquiring components and joining/assembling these individual parts. Low-cost pluggable low loss connectors are needed for connecting single mode fibers to each other and to silicon photonic devices. Thus, achieving lower cost requires defining the details of the application needs, so that specific processes can be developed and improved.

Silicon photonics has the potential to enable higher data rates with lower cost; however, multiple suppliers are developing competing solutions that are not interchangeable. Since data centers need multiple suppliers, it will be important to develop standards that enable pluggable replacement of components at some level. Even though different silicon photonic manufacturers use different manufacturing processes, the components need to operate inter-changeably.

4.2. LONG-TERM CHALLENGES

4.2.1. RF LONG TERM CHALLENGES

The biggest challenge for RF is to cost effectively increase the energy efficiency of >10GB/s communication for mobile devices. The energy efficiency of power amplifiers and DAC/ADCs decreases at frequencies above 10GHz. With 6G frequencies projected to be above 100GHz new technologies and circuits are needed to improve energy efficiency, but cost will need to be reduced for mobile devices.

4.2.2. OPTICAL INTERCONNECT LONG TERM CHALLENGES

In the longer term, standard interfaces will need to be developed for a number of high-performance optical interconnect technologies. To eliminate multiple optical-electrical-optical conversions in routing signals, optical information processing and logic needs to be developed. To increase optical processing density the third dimension needs to be utilized, as shown in Table OSC-3

The longer-term challenge that needs the most research is to enable optical routing functions. As mentioned earlier, significant time and energy is expended in converting optical signals to electrical signals in a router, decoding them to set the path and then converted to optical signals that are launched on the new path. Hybrid electrical/optical routing capabilities have been demonstrated in research to establish optical routing paths. More advanced capabilities with all optical routing may be capable of dramatically reducing the latency of communication between a CPU and memory or other CPUs.

Reducing latency in communication in data centers could enable applications of new architectures for communication between servers. Electro/optical routing is used in telecommunication and has been demonstrated with multiple technologies (i.e., MEMs) in “edge” applications. Thus, introduction of hybrid E/O routing in data centers may be efficient for sending large data streams.

If it were possible for optical logic to decode the routing instructions and change the optical path, this could significantly reduce the latency and potentially the energy of optical routing in a data center or local area network. Research is needed to identify materials, structures and devices that could perform optical logic such as decoding instructions, identifying paths that are available and switching the optical data stream to a new path.

Table OSC-3 Difficult Challenges

<i>Near-Term Challenges: 2019–2025</i>	<i>Description/ Summary of Issue(s)</i>
Achieving high frequency, energy efficient ADC/DAC technology compatible with CMOS processing.	<ul style="list-style-type: none"> • ADC efficiency degrades at sample rates above 50G samples/s (200Gb/s).
Components to meet 5G Performance Requirements.	<ul style="list-style-type: none"> • Increasing energy efficiency of amplifiers while increasing operating frequency. • Antennas to support multiple band communication in compact mobile devices. • High efficiency directional antennas are needed to increase range with low input power.
Integration of ASIC switches with optical I/O	<ul style="list-style-type: none"> • Development of self-aligning high density multi-fiber to package connectors with <1dB loss. • Integration of high-density silicon photonics into the package with ASIC switch. • Lasers integrated on silicon photonics could require high electrical power and have lifetime issues with the ASIC thermal generation. • Having the laser separate from the ASIC package requires additional fiber connections and optical routing within the package. • Compact low-cost reliable parallel optical connector SMF-to-silicon-photonics-circuits, with large number of fibers (>16)
Agreeing on standards for silicon photonic form factor and interfaces.	<ul style="list-style-type: none"> • Multiple manufacturers are developing competing solutions. Multiple manufacturers are developing competing solutions. • Technology development is expensive. • The market is small, so little incentive for competitors to develop standards.
5G mm Wave Noise Cancellation.	<ul style="list-style-type: none"> • White noise is expected to be 30–36 dB higher than 4G, so circuits are needed to cancel the noise.

	<ul style="list-style-type: none"> • High density of RF signals are expected to interfere with mmWave communication, so circuits are needed to cancel these signals. • This may require use of noise phase resonators (e.g. photonic resonators) with multiple clocks.
<i>Long-Term Challenges: 2026–2034</i>	<i>Description</i>
Increasing the density of silicon photonics to reduce cost while reducing power consumption	<ul style="list-style-type: none"> • Optical devices are often linear or planar yet much could be done, especially to reduce size, utilizing the 3rd dimension. • Design, but specially fabrication in “Z” is “hard”. Some type of 3D printing might enable this technical solution. • Developing low power higher efficiency lasers and modulators requires new technology.
Develop methods for communication between systems with different wavelengths, polarizations, modulations.	<ul style="list-style-type: none"> • Technology is needed to up or down shift photons to different wavelengths. • Technology is needed to change polarization of light when entering a different system. • Devices are needed to translate and transmit photonic modulated information to a system with a different modulation scheme (i.e., Modulation Converters).
Reducing latency of communication between CPUs and memory or other CPUs in data centers.	<ul style="list-style-type: none"> • Signals from the CPU must be serialized, converted to photons, and (photons converted to electrical be routed then converted back to photons multiple times). • Switches must arbitrate between conflicting routing request that adds latency. • Regenerate digital signals in the optical domain without returning to the electronic domain, a capability that is likely to require non-linear optical materials. • Perform logic operations in the optical domain. • Identify a strategy for reliable O/I with point-to-point connectivity. • May need a hybrid switch for small packet vs. large file messages.
Increasing energy efficiency of communication above 10 Gbps for 6G cost effectively.	<ul style="list-style-type: none"> • Identifying an energy efficient communication architecture and protocol. • Developing energy efficient components to support high data rate communication for 6G

5. TECHNOLOGY REQUIREMENTS

5.1. SUMMARY

In the IoE, communication from IoE device applications to the cloud is conducted with wireless, conventional copper, and optical interconnects. Within data centers, the cloud, communication is performed over copper and increasingly over fiber optical links and there is a need to increase data rates to support increasing traffic volumes. Increased use of artificial intelligence to learn on huge data sets is creating communication bottlenecks in data centers and high-performance computing centers, so new communication architectures may need to be developed to mitigate these bottlenecks. For IoT applications, the communication needs will vary significantly depending on the amount of data to be sent and speed of communication with the cloud. Often, a performance leading application will drive the development of new high-volume capabilities and these will be adopted later by other applications. For optical interconnect technology, the potential high-performance high-volume driver is within data center communication. For RF wireless communication, the volume drivers have been mobile smart phones; however, autonomous vehicles may emerge as a high data rate wireless communication “driver” in the near future. Thus, these needs of each application are discussed in more detail in the sections below.

5.2. DATA CENTER

The 21st Century is clearly characterized by the explosion of requests for computing, storage and communication. This has been mainly driven by the worldwide spreading of fixed and mobile systems' capabilities that have brought any kind of information, such as voice, data and video, available to anybody, anywhere and anytime.

Data Center infrastructure has become one of the faster growing areas for IT networking. Annual global data center IP traffic will reach 8.6 zettabytes (715 exabytes [EB] per month) by the end of 2018[1], up from 3.1 zettabytes (ZB) per year (255 EB per month) in 2013. Global data center IP traffic will nearly triple (2.8-fold) over the next 5 years. Overall, data center IP traffic was forecast to grow at a compound annual growth rate (CAGR) of 23 percent from 2013 to 2018. A key requirement for data centers is the need for low cost, high performance, high density, and low power networking connections. In this environment, a dramatic 'bottleneck' is the difficulty in moving massive amounts of digital information, at each scale of dimensions: from worldwide links to chip-to-chip and even intra-chip interconnections.

A major issue with data center networking is once a data center is "wired" with active optical cables, the maximum data rate of the center is fixed even though server data rates can be increased when they are periodically upgraded. Thus, server communication data rates can only be upgraded by rewiring the data center, which is a major undertaking.

For new communication technologies to be integrated into data centers in high volume, technology must be established that offers performance, power and cost advantages over existing approaches. It must be determined whether the optical transceiver should be integrated at the board, card or package level to provide these advantages. Also, the new transceivers must be optimized to minimize cost and power consumption in its application in the data center. Several new topologies are being evaluated to improve data center communication and new optical transceivers must effectively support each of these.

Switching port density is increasing rapidly to and above 128 ports; however, the space allowed for connectors is not increasing and there is also a desire to allow the continued use of legacy connectors. Furthermore, as more ports are added to switches, the power is rapidly increasing with a significant amount of power to communicate with optical I/O that is mounted on the board. Thus, alternative technologies are needed that enable more servers to communicate with the switching systems.

With increased use of application specific integrated circuit (ASICs) processors, there is demand for higher bandwidth higher data rate communication. Quantum computers may be integrated into data centers and HPC centers and would need to communicate with servers and possibly ASIC processors. To solve large problems may require many quantum computers to be communicating to appear as one large QC. This would require very high speed parallel communication paths and optical networks may need new I/O to communicate with the quantum bits.

For the sake of simplicity, the data center application areas can be separated into two categories: Outside of Rack and Inside of Rack.

5.2.1. OUTSIDE OF RACK

At this level, the issue of interconnecting the enormous number of server and storage equipment inside Mega data centers, for instance those built for cloud computing applications, is addressed. From the networking architectural perspective, a noticeable transition is underway from a rigid infrastructure interconnecting several levels of switches and routers with different capacity to a much flatter and more flexible mesh, the so called "spine-leaf" architecture that is able to directly link each rack to any other, in relatively large portions of the data center. This provides a considerable reduction in the latency of the overall system, providing much more effective services to the users.

In this scheme, for the rack-to-rack communication, different requirements may be drawn for at least 3 different transmission distances, indicatively: 10 meters, 500 meters and few (1 or 2) kilometers. The differentiation arises from the necessity to optimize the dimensions, the power consumption and the performance of different kind of transceivers, the so-called *optical modules*.

Many module form-factors are currently adopted, for instance those belonging to CFP and QSFP families, which have become industrial standards. Such pluggable solutions provide the highest level of flexibility, in terms of quick upgrading of the optical ports' speed and easiness of interconnection to the optical infrastructure, through pluggable passive optical connectors. The choice of Single Mode Fiber has already been well accepted everywhere.

For the shortest range of distances, i.e. few tens of meters, VCSEL based multimode fiber is used in active optical cables (AOC). In this case the E/O and O/E conversions are implemented inside the 'connector' of a fully terminated cable. These active connectors have the same form factor as many of the optical module connectors, e.g. CFP or QSFP, as shown in

Figure OSC-2. The user can therefore adopt this cabling system as a straightforward replacement of copper cables, but at much higher capacity and higher performance in terms of the signal integrity while reducing the size and power of the cabling.

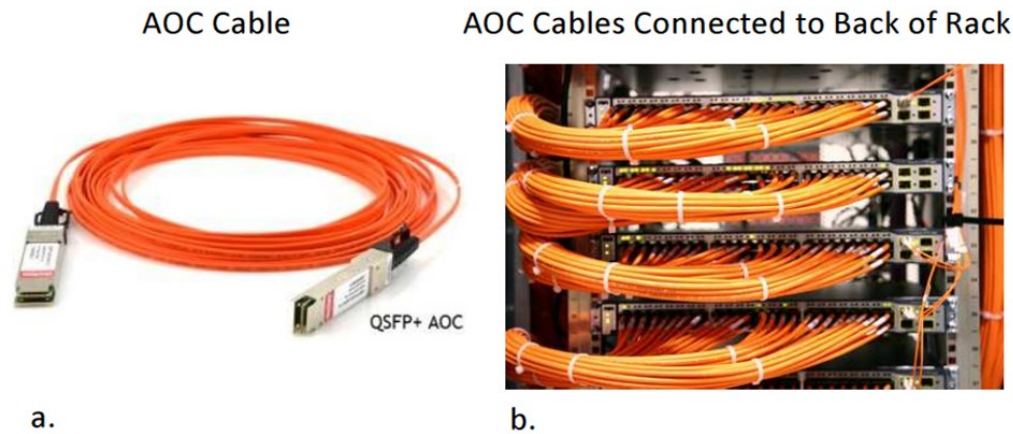

Figure OSC-2 a. Active Optical Cable (AOC), here with multimode fiber, and b. AOC Connected to Back of Server Rack in Data Center

Finally, the necessity to interconnect the data centers to the rest of the world calls for a different kind of transceiver modules, transmitting/receiving at much longer distance ranges (10's and 100's of kilometers). But these can be considered belonging to the Telecommunication segment.

For longer distance communication with optical modules, the data rates per lane (per single wavelength) must increase as shown in Table OSC-4. As data rate requirements increase and lower power is required with AOC (Table OSC-5), the components must still fit into a very small form factor, which will become increasingly difficult.

[*Table OSC-4 Wavelength Division Multiplexing Module Performance Requirements*](#)

[*Table OSC-5 Data Center Outside of Rack Requirements and Potential Solutions*](#)

5.2.1.1. OUTSIDE OF RACK CHALLENGES

The challenges are very similar for all the different kinds of optical transceivers listed above: in the first instance, dimensions of optical modules and power consumption, in terms of energy/bit reduction, are of paramount importance to provide an ever-increasing throughput capacity at the front panels of racks/boards. Then, the performance, in terms of ever-increasing bit rates and quality of signals, in terms of very low BER (Bit Error rate), are necessary to guarantee a fully reliable interconnecting mesh. Last, but not least, the low cost, in terms of \$/bit, is fundamental to make affordable and convenient to use photonics in this application area. A significant challenge for data centers is to simplify the effort required to upgrade the data rates when new servers are installed in the data center.

Switching systems are continuing to rapidly increase the number of ports that can communicate with servers or other switches; however, the space on the face plate for connectors is not increasing. As the data rates and number of ports in the switches increase, power to drive communication across the board to the photonic I/O is becoming significant and difficult to manage. With switches approaching 51.2 Tbps, the power to drive signals through a board to AOCs is becoming too large, so there is considerable effort to integrate optical I/O on the switch package. While there is a desire to continue using legacy connectors, new cable/connector technology is needed to support continued growth of switching matrices. Furthermore, short range communication in data centers is dominated by VCSEL-based multimode communication, due to lower cost and power than single mode edge emitting lasers. So, the question is whether switches with optical I/O would need to support multimode connectors for short range communication with longer range communication with single mode fiber, or will single mode communication become power and cost effective to support short range communication?

10 Technology Requirements

For analysis of “Big Data” and high-performance computing, it is important to have a large number of servers that can communicate with low latency (<300ns). The latency time is defined as the delay between an information request being generated by the server and the information being returned to the requesting server. Thus, many factors reduce the distance between servers including data encoding, DAC and ADC time, laser and detector signal conditioning, switching delay and the delay through the fiber.

5.2.1.2.NEAR TERM POTENTIAL SOLUTIONS

Near term solutions include increasing data density in optical cables. For shorter distance communication between servers and switches (30m), multimode fiber with pulse amplitude modulation [2] may have a power and cost advantage over single mode and research has demonstrated VCSEL based communication with PAM4 of 160Gb/s over a 1km multimode fiber [3]. Non-return to zero (NRZ) modulation of VCSELs has been demonstrated to deliver 71Gb/s communication without error correction [4]. On the other hand, silicon photonic heterogeneously integrated products have four or more wavelengths per fiber, as shown in Figure OSC-3, which may become competitive at higher data rates. For longer distance communication silicon photonics may operate at higher frequencies or integrate more wavelengths per module. In the near term, this would enable increasing data rates to support the roadmap.

In the future, HOM (High Order Modulation) techniques can be adopted to increase the spectral efficiency, providing very high-speed transmission per lane (fiber or wavelength).

Developing on-card or on-package optical interconnects would potentially enable connecting single mode fiber to the new server that would then be transmitted data at the new higher data rate of the server, reduce the energy required, and reduce the weight of the PCB due to reduced copper in the board.

To support the growth of switching matrices, new “Break Out” cable connectors have been proposed that would allow multiple servers to communicate through a single switch port. This or similar technologies could support continued growth of switching matrices without changing their shape or connectors.

To reduce the power required for higher I/O count switches, integration of the photonic I/O into the switch package could reduce the switch I/O drive power required. It is not clear whether photonic I/O would be a combination of multimode VCSELs (short range) and edge emitting single mode lasers (longer range) or eventually only single mode edge emitting lasers. In either case, the cost and power consumed by the photonic I/O integrated in the switch package will need to be reduced. Also, the temperature of the photonic I/O will need to be controlled as high order modulation is employed.

5.2.1.3.LONGER TERM POTENTIAL SOLUTIONS

Reducing the power and reducing cost required for photonic interconnects will be important to increasing data rates. Potential options to reduce cost and increase bandwidth include development of hybrid electrical/optical routing or all optical routing. Hybrid electrical/optical routers have been demonstrated using electrically activated MEMS devices to route optical data streams;[5, 6, 7] however, the time to realign each MEMS switch is ~11–13 μ s. A different approach to reduce cost was to employ digital micromirror devices (DMD) with free space routing mirrors suspended above the servers that directed the optical signals to detectors on the target server racks[8]; however, the time to align mirrors is still 11–13 μ s. Faster E/O hybrid routing has been demonstrated using Mach-Zehnder modulators with semiconductor optical amplifiers (SOAs) and projected switching times of ~1ns[9]. Mach-Zehnder interferometers have been integrated with thermo-optic phase modulators, CMOS logic and device drivers with switching times of ~1ns.[10] Analysis indicates that an E/O router with microrings could be fabricated in a 128 X 128 router with a reconfiguration time of ~1ns.[11] All optical routing has been demonstrated with amorphous silicon microring resonators with ps switching times[12].

In the future, use of more compact energy efficient lasers and modulators will be critical to supporting lower cost more energy efficient optical routing. Nanostructured lasers have demonstrated higher light output with lower energy consumption. Also, lower power modulators including, ring modulators, electroabsorption modulators, plasmonic Mach Zehnder modulators, or other novel modulators have the potential to enable high density low power modulators. At the basis of this evolutionary path will be, obviously, the availability of 2D and 3D opto-electronic devices.

In the longer time frame (i.e., >10 yrs.), potential implementation of hybrid or all optically based switching and routing could enable new types of architectures for communications, as have been evaluated with hybrid routers, [5, 9] within data centers without intermediate optical-electrical-optical conversions.

To support low latency communication (<300 ns) between many servers for high performance computing or big data analysis, all optical routing is an option that could potentially have the smallest increase on latency. One proposal is to have each server assigned a specific wavelength with a router consisting of a grating to passively direct wavelengths to the targeted server fiber [13]. The number of servers that could communicate would be limited by the number of wavelengths

that could be sent and directed through the router. If a destination header would need to be decoded optically or electrically, this would further reduce the number of servers that could be connected.

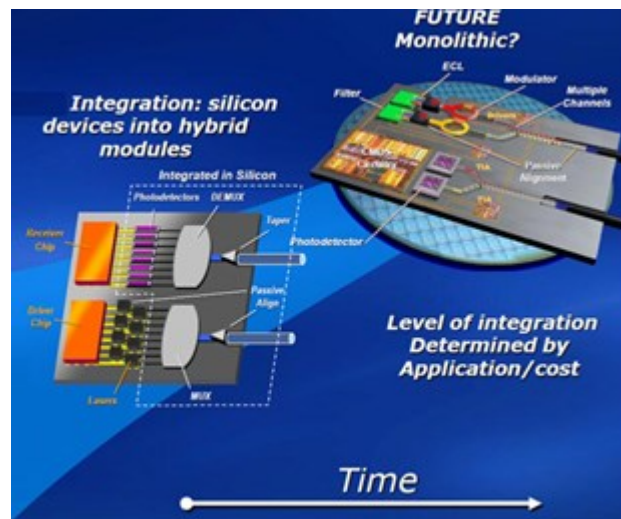

Figure OSC-3 Potential Integration of Advanced Optical Interconnect Technologies Over Time

Note: Presented by Intel at 2013 Intel Developers Forum.

5.2.2. INSIDE OF RACK

Clearly, the enormous data rate throughput running across the data center, as described in the previous paragraph, is generated inside each piece of equipment in the data center itself. Copper is already showing severe limitations in terms of attenuation and available bandwidth and it becomes increasingly difficult to communicate at high data rates on PCBs (Printed Circuit Boards), unless unsustainable power consumption levels are used. Optical interconnects will displace copper interconnects over time. The optical I/O will probably be used first for the cards or the chip/package I/O, as illustrated in Figure OSC-4.

At each stage of this transition, the opto-electronic components will need to be integrated into smaller form factor packages. Pure electronics and hybrid opto-electronic integration appear to be ineffective when a drastic level of miniaturization has to be realized, when performance at hundreds of Gb/s is to be met, and whenever the costs of implementation of pure optical devices, based on expensive materials, are to be drastically cut.

New efforts for advanced opto-electronic integration will be required to implement the so-called ‘embedded modules.’ These type of optical transceiver modules will be fabricated in ultra-small dimensions, so that it will be possible to mount them very near (i.e., <1 cm) the big digital ASIC hosts. This arrangement will optimize throughput and will eliminate the power consumption implied by high-speed copper interconnections. It must be determined whether the “embedded modules should be mounted on the board, card or integrated into the ASIC package to deliver the best performance and lower power consumption. For these new modules to be adopted in data centers, technology must be developed that supports serviceable repair or replacement of the components.

As mentioned earlier, the switch (routing) chips have a significant need for increasing data rates with increasing I/O counts while reducing power density.

12 Technology Requirements

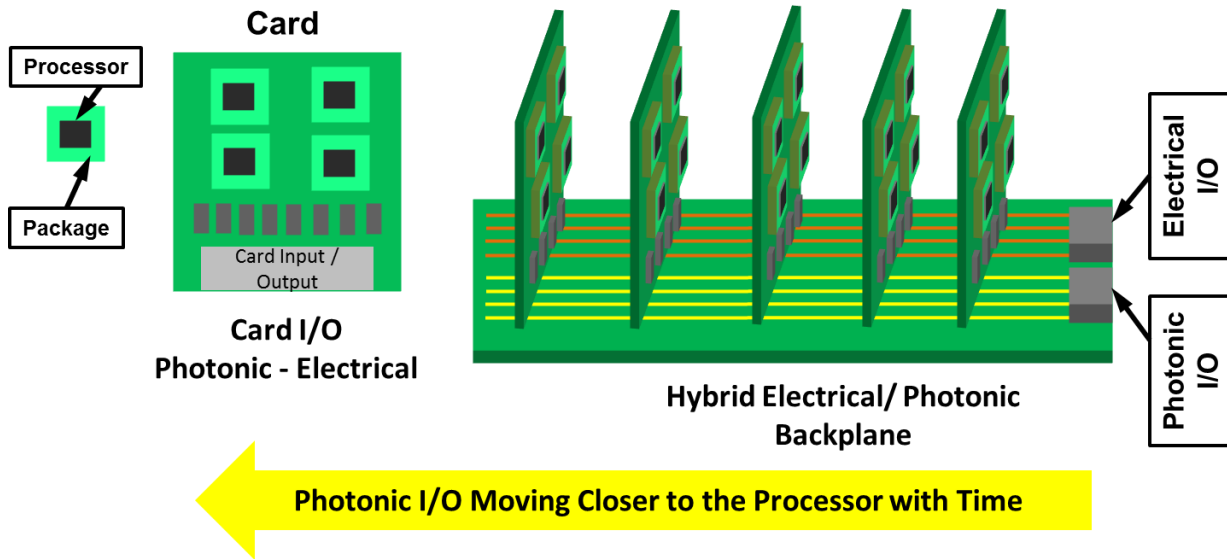

Figure OSC-4 Evolution of Optical Interconnects to Shorter Distances Depends on Cost, Data Density, and Added Latency of Electrical-Optical-Electrical Conversions

Table OSC-6 [Data Center Inside of Rack Requirements and Potential Solutions](#)

5.2.2.1. INSIDE THE RACK CHALLENGES

The challenges are in achieving the increased levels of miniaturization and energy dissipation/bit for the opto-electronics; moreover, the cost/bit will have to be less than that of copper-based devices and systems for a widespread adoption, as shown in Table OSC-6. From the pure optical point of view, the coupling of optical signal with fibers and waveguides will become crucial for the good operation, at the required industrial reliability.

5.2.2.2. INSIDE THE RACK NEAR TERM POTENTIAL SOLUTIONS

Near term solutions will adopt 'silicon photonic embedded-modules' with optical fiber pig-tails. According to the availability of optical PCB boards this kind of ultra-compact transceivers could evolve with the capability to avoid interfacing with optical fibers while interfacing directly with 'optical' PCB embedding waveguides that will substitute for fibers. In the near term, multimode waveguides embedded in PCBs are possible, while single mode waveguides are desired, they require significant work and may be a longer-term solution.

For sub-meter distances, optical interconnection will be a real must. In this perspective, silicon photonics technology is shipping in high volume and higher performance products are being developed. In the near future a commoditized use of the silicon photonics technology, as presently happens for traditional VLSI market will be available on the market.

Multimode optical interconnects currently provide low cost, low power short range optical interconnects; however, some are proposing to use single mode on/off board optical interconnects. A few manufacturers are offering single mode AOCs that support longer range communication (200 m to 4 km) with low power consumption. The significantly tighter alignment requirement of single mode photonics makes achieving multimode cost very difficult for shorter range optical interconnects. Thus, multimode and single mode optical interconnects are potential solutions to on/off board optical interconnects, but if only short-range communication is required multimode at 850 nm may have a significant advantage over single mode. While silicon photonics offers the potential to have multiple wavelengths and modulations in a single mode fiber, multimode VCSELs have been demonstrated to support pulse amplitude modulation (PAM4) [14] with 100 Gbps/wavelength (lane).

With routing chips, potential solutions to reduce power are to integrate optical I/O into the package with the routing chip. Integration of silicon photonic I/O in the routing chip package has the potential to meet the I/O density and power requirements of these devices. Proposed options include integrating direct driven multimode VCSELs or single mode silicon photonic I/O in the package with the routing chip. Expanded beam connectors have been proposed to connect the optical I/O with the fiber network, however, the single mode options are more challenging than multimode connectors.

5.2.2.3. INSIDE THE RACK LONGER TERM POTENTIAL SOLUTIONS

In even longer timeframes, the final goal will consist of embedding optical I/O's in the digital ASIC's: optics will definitively support all communication among VLSI devices.

To reduce power and cost, full range of optical devices will evolve to smaller, higher density, structures with higher data rates: long term novel laser structures, electro-optical modulators or novel Mach-Zehnder, or plasmonic Mach-Zehnder, modulators and detectors are needed, as shown in Table OSC-6 potential solutions. For lasers, it is important to reduce energy dissipation, increase optical power output and increase operating frequency for direct modulation, and nanostructured lasers have the potential to meet this need. For modulators, it is critical to increase on/off ratio, to reduce size, to have high operating frequency, energy dissipation and optical loss. There are several options for reducing the optical switching power and increasing switch density including, ring modulators, electroabsorption modulators, plasmonic Mach Zehnder modulators, or other novel modulators. Each of these modulator technologies have their own challenges and will be discussed in more detail later.

Again, expanded beam connectors provide potential solutions to connecting the silicon photonic I/O with the fiber network from either the package, card or printed circuit board level.

5.3. HIGH PERFORMANCE COMPUTING

High performance computing is used for a wide range of applications including discrete event simulation, physical system simulation, optimization, etc. Each of these application types have different needs for communication bandwidth, data rates and latency of communication. To analyze many of the problems of interest to HPC users, machine learning is increasingly being applied. Since each of the applications may require a different network configuration, the network must have flexibility to ensure fast changes of configuration to enable optimal performance for each problem.

High performance computing (HPC) users have long understood the value of machine learning (ML) and today's hardware is able to finally deliver on these promises. One of the key desirable aspects for ML is the ability to broadcast data during the reduction step of ML or, as another example, during the scatter/gather steps of a sparse matrix multiplication. The lack of a scalable interconnect that enables a large (greater than 64 nodes) all-to-all (A2A) topology has created significant bottlenecks in the performance of such machines. Graphic processing units (GPU) do an excellent job of circumventing such a bottleneck by dense integration of compute nodes (GPUs in this case) to minimize the length and use of copper interconnects. However, this approach is faced by power density challenges as each GPU can consume greater than 250 W, thus creating a 64-node box that is drawing more than 16 kW alone. This is a difficult thermal management problem.

One obvious solution to this problem is the use of photonics, such as active optical cables (AOCs) that can circumvent the reach problem and reduce the power density. However, these devices are still not power efficient enough, which present power consumption and thermal challenges of their own. Furthermore, once connected, topologies built with AOCs are a static network; clearly the use of switches in such a deployment is a non-starter due to the associated latencies, often greater than 300 ns.

Co-packaged optics, either using vertical cavity surface emitting lasers (VCSELs) or silicon photonics using integrated off-chip lasers, present the next level solution as compared to AOCs. They offer reduce power consumption by tighter integration with the compute node. For example, by using a multi-chip module assembly, the compute node can communicate via XSR standard electrical link (rated for 112 GT/s, 1 mm of reach and 1 pJ/bit power consumption) with the electro-optic engine. Furthermore, co-packaged optical interconnects can enable a dynamic network by virtue of both space and wavelength division multiplexing (SDM and WDM, respectively). By carrying multiple wavelengths on a single fiber, one single fiber connection can enable a plurality of intra-node communication that is software-defined per the epoch of the application running on that HPC machine. This holds the promise that a typical ML application can have one topology for training and another, different, topology during inference. This capability breaks the difficult choice often faced by customers on whether or not buy a system that is optimized for one task or another.

5.4. QUANTUM COMPUTING AND COMMUNICATION

Unlike classical bits, which have a value of either 1 or 0, quantum bits, or 'qubits', can be in a state of superposition, meaning that they can represent multiple combinations of 1 and 0 simultaneously. Quantum processors perform operations on qubits. Quantum computers perform quantum computations using quantum processors with multiple qubits. Quantum computing capacity grows exponentially with the total number of qubits, so there can be significant benefits to connecting quantum computers using a quantum network.

Quantum communication involves the generation and distribution of quantum information between quantum processors. The quantum information can be as simple as a single qubit in the form of a photon. More complex forms of quantum

14 Technology Requirements

information used in communications include entangled pairs of particles, typically photons, which are generated with a shared quantum state. Some applications of quantum communications require only very modest quantum processors. For example, quantum internet protocols such as quantum key distribution (QKD) require only processors capable of preparing and measuring a single qubit at a time. Improved security is possible because single photonic qubits carry the information, and any interception or readout of the qubit can be detected.

Optical communications networks are also expected to have applications within quantum computing systems. While quantum computers are still under development using a variety of competing technologies (e.g., superconducting, trapped ion, optical, quantum dot), some naturally use photonics (e.g., trapped ions, optical) and others operate at extremely low temperatures with a limited cooling capacity and cannot afford many electrical interconnects between room temperature and the cold space (e.g., superconducting, quantum dot).

A more detailed discussion on quantum information processing is in the IRDS chapter on [Cryogenic Electronics and Quantum Information Processing \(CEQIP\)](#).

5.4.1. CHALLENGES

Quantum computers have both opportunities and challenges for optical interconnects [15-17]. Gate-based quantum computers will require an estimated 1000 logical qubits to perform significant benefit. The number of physical qubits required to make a logical qubit varies by qubit technology and might range from roughly 10 to 1000. Each physical qubit requires control and readout, which requires optical, microwave, voltage, or current interconnects, depending on the qubit technology. Challenges for qubit technologies that use photonics (e.g., trapped ions, optical) include scaling the photonic controls to the small sizes necessary and reducing the error rate during qubit readout. Challenges for qubit technologies that operate at extremely low temperatures (e.g., superconducting, quantum dot) include increasing the low temperature optical to electronic (OE) and electronic to optical (EO) conversion efficiencies.

Quantum communications systems are sensitive to the loss or disturbance of single photons, which is both the foundation for their security and the source of many challenges. Increasing the effective data rate and communications distance will require improvements in photonic qubit generation, transmission, and detection. Standard telecom fibers or free-space transmission can be used with photonic qubits. Quantum communications between quantum computers based on other qubit technologies might require different wavelengths for optimization. Optical qubit switches need to operate without affecting the qubit state, which makes them more challenging to realize than standard optical switches. Quantum repeaters are required to transport qubits over long distances. Qubits cannot be copied due to the no-cloning theorem, so quantum repeaters are fundamentally different from classical repeaters.

Quantum networks will likely need to communicate between quantum processors using different types of qubits if different qubit technologies are required to provide both rapid computation and long-lived states (quantum memory) [18]. This will require communication that is completed with a latency that is much shorter than the coherence time of the qubits in the systems. This is a significant challenge that requires research into new physical methods that don't disturb qubit states when reading, but align states when receiving input from other qubits.

5.4.2. POTENTIAL SOLUTIONS

For communicating qubit states in cryogenic systems to conventional electronics, communication of laser light to a cryogenic photodetector has been demonstrated [19]. Conversion of superconducting transmon qubit microwave excitation into an optical photon has been demonstrated without changing the state of the qubit [20]. Other reports demonstrated both optical input and output from a superconducting qubit [21]. These laboratory demonstrations offer promise for potentially scaling up optical I/O with superconducting qubits in the future.

For entanglement between qubits on different substrates, this has been demonstrated with qubits on different silicon substrates [22]. Although the distances are quite short, this offers hope that entanglement could be established between systems over longer distances. Significant research is needed to identify physical phenomenon that could enable bidirectional communication between qubits in different systems.

5.5. TELECOMMUNICATION

Telecommunications will continue to support increasing data volumes both to data centers, offices, RF base stations, and FTTX to support home users. To support this increased volume of data, the data rate per wavelength will need to increase from the current 400 Gb/sec-wavelength to 2000 Gb/s.-wavelength in 2029. The maximum data rate per fiber will increase from 100 Tb/s to 250 Tb/s in 2027 as shown in Table OSC-7, which requires over 100 wavelengths per fiber and modulation of polarization and higher order modulation. The telecommunication industry is leading the development of these technologies.

Table OSC-7 [Telecommunications Optical Interconnect Requirements](#)

5.6. LAST KM OR MILE COMMUNICATION

The last “mile” communication to homes and offices is done with multiple copper solutions, fiber (FTTX) or RF. As data rates are increasing, fiber and RF are becoming more attractive and are competing to deliver cost effective solutions.

5.6.1.FTTX

FTTX uses fiber to “feed” copper to provide the last 1–2 km of the data and tele-communication connections to the end user. As data rates have increased, providers have extended fiber closer to the end user to overcome limitations of copper interconnects. While the downlink data rate is only expected to increase from the current 10 Gb/s-wavelength to 100 Gb/s-wavelength, the maximum number of wavelengths per fiber is expected to increase from 4 to 10, as shown in Table OSC-8. As the fiber is extended closer to the user, multiple wavelengths in the fiber will need to be separated by a DeMUX in contact with the fiber. Furthermore, the signals launched from the user will need to be duplexed with other wavelengths in the fiber returning data to the communication switching center.

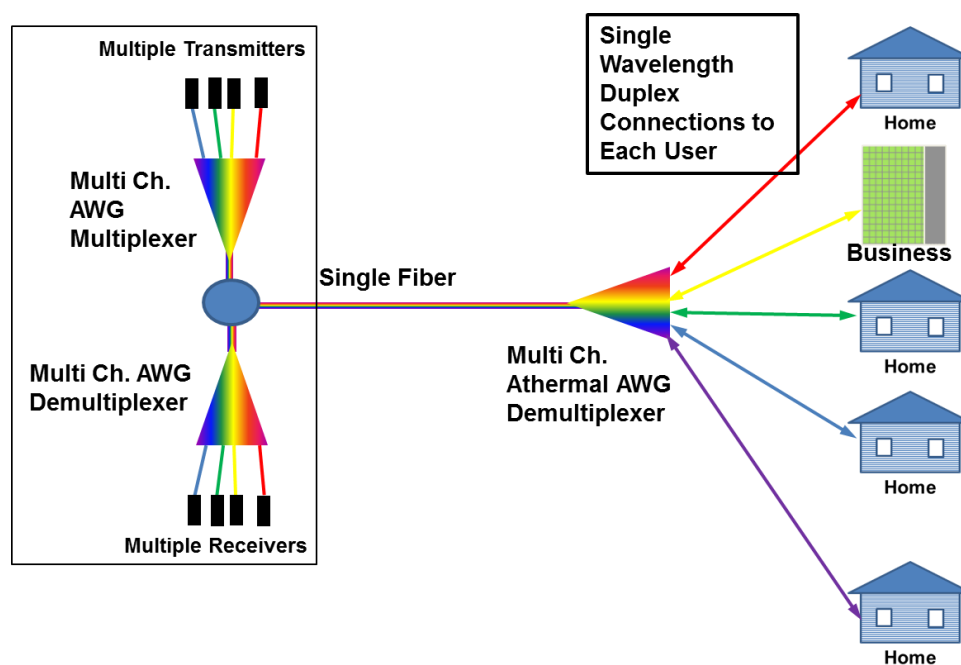
Table OSC-8 [Fiber to X \(FTTX\) Requirements and Potential Solutions](#)¹Figure OSC-5 *Potential Path for FTTX Extending Further from the Telecom Office to Businesses and Homes*

Note: This requires wavelength division multiplexing (WDM) and demultiplexing closer to the point of service delivery. Electrical wires may be used to deliver the last length of connection to some customers.

5.6.1.1.FTTX CHALLENGES

The biggest challenges for the FTTX optical interconnects are to develop cost-effective compact MUX and DeMUX capabilities that can split compactly separate wavelengths and merge wavelengths from users to the switching office.

5.6.1.2.FTTX POTENTIAL SOLUTIONS

Potential solutions include developing compact Mach Zehnder MUX and DeMUX capabilities based on plasmonic technology or other compact technologies. It is assumed that silicon photonic modules and other improvements in lasers, detectors and modulators to support data centers and Office LANs can be adopted to support FTTX. Compact integration technologies to support integrating modulators in AOC can be adapted to support FTTX applications.

¹ 802.11ay is projected to be approved November 2019: http://www.ieee802.org/11/Reports/tgay_update.htm

5.6.2. WIRELESS

In these environments, data and communication may be delivered to the office or home with wire, optical fiber, or wireless, but wireless will most likely be used to connect to computers, smart phones, smart appliances, tools, business terminals, power management, environmental monitor and control systems, and IoT products. This includes applications such as exercise and health monitors and passive activity monitors for elderly citizens. With increasing numbers of devices communicating to and through these networks, the routers will need to communicate with a range of protocols and have ever increasing bandwidth. Security will become an even more important issue to keep unwanted monitoring or malicious interference from outside wireless devices as more devices are monitored and controlled over the network.

5.7. OFFICE AND FACTORY LOCAL AREA NETWORKS

Offices and factories will have ever increasing need for bandwidth as more information is being transmitted by the internet of things devices and analyzed to improve business performance. Offices will require conventional services including messaging, virtual meetings, and access to data from the “cloud”, to analyze customer requirements, product availability, product performance (IoT) reports, etc. This will require increasing bandwidth over time that will require a combination of optical and wireless communications technologies, as shown in Figure OSC-1. In factories, information will be communicated between the tools in the manufacturing flow and manufacturing control where performance of individual tools will be monitored and issues “flagged”. This will require a local area network with connection to individual manufacturing tools, manufacturing control, technicians and engineers. The network should include a high bandwidth optical interconnect “back bone” connected to manufacturing control, fixed tools, and engineering analysis stations. Wireless connection could be used for communication with low data rate manufacturing tools and material handling systems that are mobile. The configuration of optical and wireless communication technologies will depend on the requirements of the office, factory, or warehouse. Optical interconnect technologies to be used could include high bandwidth fiber and/or a free space optical interconnect system (LiFi) with a wide range of wireless technologies including Wi-Fi, Bluetooth, LPWAN, custom wireless, and new wireless systems including 5G.

Medical facilities, such as hospitals, may have some tools or operating room areas that are sensitive to RF and EMI, so they may limit communication to shielded wire or optical interconnects for connectivity.

Since many technologies may be required to support these applications, only the optical interconnect LAN requirements will be discussed in detail in this section and others will be discussed in separate sections.

Table OSC-9 Office and Factory LAN Requirements and Potential Solutions

5.7.1. OPTICAL LAN NEEDS

The optical interconnect LAN requirement is projected to increase from current data rates of 100 Gb/s-wavelength with four wavelengths to 200 Gb/s-wavelength, as shown in Table OSC-8. Over this time, the power dissipation/Gbs will need to decrease by over a factor of four. To achieve these high data rates for each wavelength new technologies are required to compress more information in a single wavelength.

The biggest challenges for fiber optical LAN are to 1) increase data rates while reducing energy/bit and 2) reduce latency due to optical-electrical-optical conversion, as shown in Table OSC-9.

5.7.2. OPTICAL LAN POTENTIAL SOLUTIONS

With silicon photonic modules becoming available, this should enable highly integrated power efficient communication. Furthermore, higher performance lasers that operate at lower power or highly efficient modulators that enable encoding more information in a single wavelength could enable evolutionary improvements in the silicon photonic modules. Furthermore, photodetectors and their amplifiers would need to operate at higher speed with lower energy per bit. Technology options to achieve higher data rates at lower power will be discussed in Section 6.

A second option for an optical interconnect LAN is “free space” optical interconnects (LiFi) that could operate using high data rate modulated LEDs[23] or lasers that are directionally controlled with mirrors or other means[24]. Several options exist for this technology that could use existing components, as shown in Table OSC-2; however, the data rates may be significantly below those in fiber as indicated in Table OSC-10. One advantage of an LED system is that it could easily communicate with machines that are moved frequently[23].

Table OSC-10 Free Space Optical Communication - Key Attribute Needs

5.7.3. WIRELESS LANS

Wireless will be used to communicate with computers, smart phones, smart appliances, tools, power management systems, and other IoT products, etc. Security will become an even more important issue to keep unwanted monitoring or malicious interference from outside wireless devices as more devices are monitored and controlled over the network. If Wi-Fi adopts higher frequency for office LANs, e.g. by increased use of the 60 GHz band, which currently is the band used by 802.11ad and the upcoming 802.11ay(a) standard, this will reduce the leakage of data from buildings and make it more difficult to eavesdrop or hack the network. Furthermore, directional antennas could focus communication to the user and thus make it more difficult to eavesdrop on private communications. Furthermore, techniques could be developed that would detect signals coming from directions and distances other than the host network.

Small Business or Home

5.8. MOBILE SMART PHONES

As smart phones incorporate more functionality, they will need to communicate at higher data rates with the internet, but also detect signals from GPS satellites, cell towers, health monitors, watches, and other RF sources, as shown in Table OSC-11. Thus, they will need to have compact antennas that can receive and transmit to multiple ranges of frequencies with multiple protocols. The RF & AMS components will need to support all of the communication with high energy efficiency for multiple applications simultaneously.

A critical need for these devices is technology that enables highly secure operation and communication with the internet and other devices.

Also, with the increasing proliferation of wireless devices, there are significant concerns that interference between signals from the many wireless devices communicating in small areas will become a huge problem in the future. Some are proposing development of novel antenna and other schemes.

Table OSC-11 [Mobile Device Wireless Performance Requirements](#)

5.8.1. MOBILE SMART PHONE CHALLENGES

A significant challenge for mobile smart phones is to support the data rates required for new multimedia applications such as virtual reality. While future smart phones need to communicate at higher data rates, they will need to operate with low power consumption. Furthermore, future smart phones will need to have improved security of personal information when communicating with the internet or other devices. An additional challenge is to integrate additional antennas into thin smart phones without causing interference in other communications or integrated circuits.

As applications require data rates higher than 10 Gb/s, the lower efficiency of the DAC/ADC and power amplifiers will make achieving communication efficiency numbers very difficult.

5.8.2. MOBILE SMART PHONE NEAR TERM POTENTIAL SOLUTIONS

In the near term, higher data rates would be supported by 5G technology that has a target of data rates >1 Gbps. The two options for this are multiple input multiple output (MIMO) at frequencies <6 GHz, or mmWave communication (28–78 GHz). Both of these technologies will require introduction of multiple antennas into the phone. Both are expected to employ directional communication from the base station to increase range while reducing interference and reducing transmitted power. A potential solution is the use of active phased array antennas to receive and transmit information. The use of directional antennas in both the base station and the cell phone may also allow implementation of methods to enhance security of communication. If 5G is initially implemented with <6 GHz, base stations would operate with massive MIMO and be able to support multiple users simultaneously, but the cell phone would operate with one or a few antennas. To improve communication throughput for the user, full duplex communication [25] is being considered to enable simultaneous transmission and reception by the cell phone and the base station. Full duplex would require new circuits to separate outgoing and incoming data.

To improve efficiency of ADC/DACs, new ADC concepts have been demonstrated that turn on converters only when processing data and operate with 6 bit accuracy and consumes 15.1 mW power consumption [26].

5.8.3. MOBILE SMART PHONE LONGER TERM POTENTIAL SOLUTIONS

In the longer term, high frequency mmWave may be used in high population density areas to support high data rate applications with a large number of users. A significant challenge is that 28 GHz to 78 GHz signals do not penetrate buildings, so buildings would need to have repeaters in the building or employ massive MIMO or ultra-high data rate Wi-Fi.

18 Technology Requirements

If 5G is implemented with mmWave and MIMO, cell phones would need to have multiple antennas to receive and transmit information and each antenna would need to have power amplifier (PA) and an ADC and DAC [27], which would consume considerable power operating with high precision at high frequencies. A critical challenge is to increase the energy efficiency of the PA at mmWave frequencies while maintaining linearity, since the efficiency of the PA decreases with operating frequency. Thus, higher performance of incumbent process technologies or even new materials may be required to improve energy efficiency, as shown in Figures OSC-6 and OSC-7. In the transmit mode, the antenna array would operate as an active phased array to focus transmission toward the base station. To overcome the high operating power of the high precision DAC/ADCs, use of hybrid analog/digital preprocessing [28, 29] or lower precision DAC/ADCs (1bit) [27, 28, 30] has been proposed. To compensate for potential blockages [31], multiple antennas would need to be integrated into the cell phone to be connected with multiple base stations.[32]

For >10 Gb/s communication rates, proposals have been made for a single bit zero crossing modulation protocol; however, energy efficiency of all required components need to be investigated.

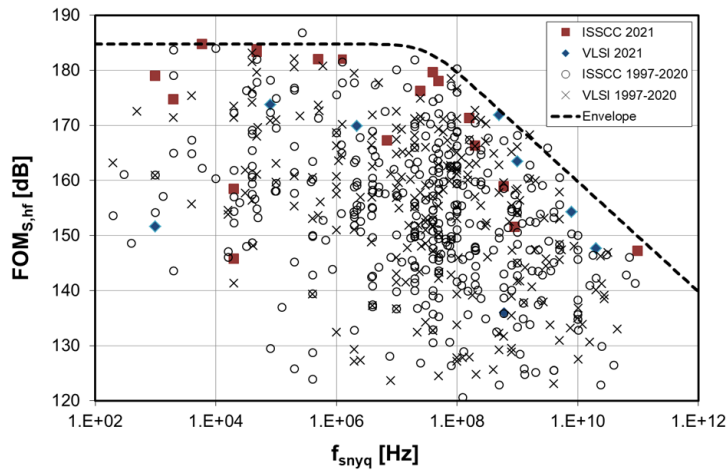

Figure OSC-6 ADC Performance Survey²

² <https://web.stanford.edu/~murmann/adcsurvey.html>

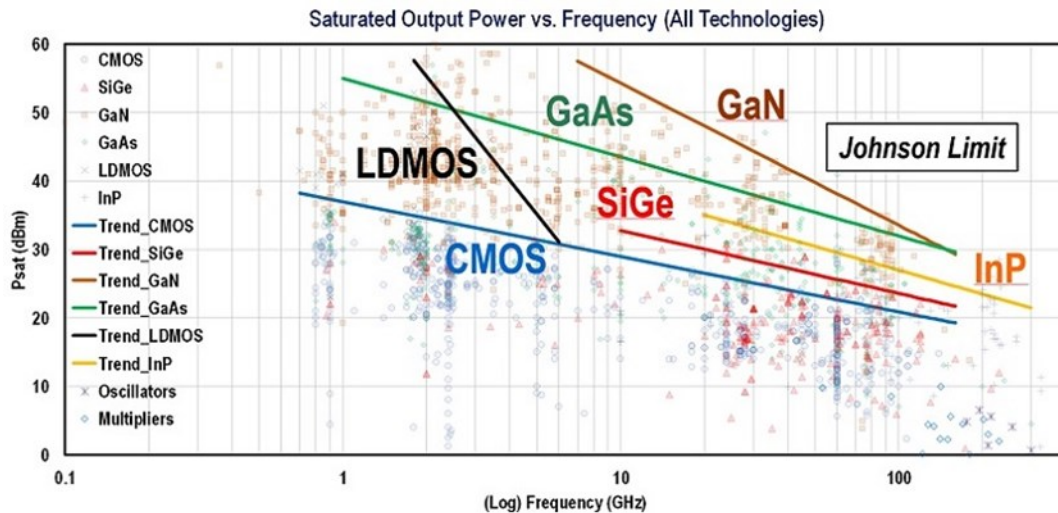

Figure OSC-7 Power Amplifier Output Power³

5.9. AUTOMOBILES

Scope: Automobiles, trucks, freight trucks, heavy equipment, and farm equipment.

Autonomous vehicles will use wireless systems to communicate with networks, determine position and detect proximity to objects and vehicles. Because of the complex conditions and weather that autonomous vehicles need to operate, they will need a multitude of sensors to identify road signs, road hazards, pedestrians, animals, and classify the threats presented and anticipate their actions. They will also need to have access to traffic information and communication with other vehicles to identify changes in traffic flow that must be negotiated. The sensors could include video cameras, RF, microwave, “radar”, LiDAR, optical range detection, sonar and others. With the large number of different sensor types, it is proposed that a sensor fusion computer analyze their raw data to develop a map of obstacles. Currently, the forward-facing video cameras require the highest data rate for the 1080i of 1.5 Gbps for raw data, as shown in Table OSC-12. As automobile manufacturers seek to provide higher resolution images at longer distances, higher resolution cameras such as 4K will require data rates of >13 Gbps per camera for communication of raw data to the sensor fusion computer.

A significant challenge is that in heavy traffic, significant blind spots will be presented by vehicles in front of the target vehicle, so communication with other vehicles and local traffic management computers will be necessary to develop comprehensive maps of obstacles in the travel path will be required. Communication of information from sensors and guidance detectors will require significant amounts of data to be transmitted and analyzed, which will require use of high bandwidth optical or wired connections, as shown in Figure OSC-8.

Some have proposed that as many as six video cameras could be used by each vehicle. A significant unknown is how much information processing will be done at the sensor or camera prior to information being sent to the sensor fusion computer. It is assumed that data being received by vehicles from other vehicles or the cloud will be either processed images or maps of obstacles, so standards need to be developed for this communication.

Table OSC-12 Autonomous Vehicle Sensor Communication Data Rates

In the long run as autonomous vehicle guidance technology matures, several possibilities seem likely. Initially few of these vehicles will be operating so each will be a stand-alone source of data. As the number of vehicles on the road grows, benefits will arise from the vehicles communicating with one another. Possible benefits include vehicles sending object location to vehicles behind them, enabling fusing the location of both stationary (curbs, barriers, etc.) and moving (cars, trucks, bikers, pedestrians, etc.) objects so object locations are known as soon as possible. That information will enable vehicles to accommodate their motion sooner and with finer detail improving the object avoidance capability.

³ H. Wang, et. al. “Power Amplifiers Performance Survey 2000 to present.” https://gems.ece.gatech.edu/PA_Survey.html.

20 Technology Requirements

As the number of autonomous vehicles increases, another potential issue is interference between the optical and maybe even RF data streams. (Imagine the density and number of signals in the air on the 10 Freeway during rush hour in southern California where the freeway is more than six lanes wide in each direction with parallel on-off ramps and several levels of fly overs.) With LiDAR and Radar that broadcast electromagnetic wave beams, some sort of coding may be needed to enable a specific vehicle to sort out its LiDAR and or Radar signal returns from the other nearby broadcasters!

As the density of autonomous vehicles reaches a critical point, it is quite likely that vehicles will communicate sensor data to traffic control local (fog computers) instead of between vehicles. Then, the fog traffic control computer will broadcast an updated real-time map of obstacles to all vehicles within its radius of influence. In areas with lower traffic densities, the vehicle-to-vehicle communication system will provide sensor data to vehicle sensor fusion systems that will provide the map of obstacles for the vehicle control system.

In the long term, (i.e., decades) when almost every vehicle, biker, pedestrian, etc. is visible electronically/digitally, one can see fusing motion data to enable merging of traffic streams at intersections, eliminating the need for traffic lights and enhancing capacity of the roads and highways and speeding traffic.

When vehicles become autonomous, they will need to be highly secured from hacking devices, and also monitor the health of the passengers to ensure that a medical emergency has not occurred, so sensors will be needed to monitor this and also potentially communicate with medical devices or smart phones. In early development of autonomous vehicles, significant amounts of data will be communicated to the manufacturer to assess actions to be taken and review decisions made by the processor in the vehicle. Security of control and passenger information will be paramount, so security systems must be able to quickly detect hacking or spoofed data that could cause danger to the vehicle and passengers.

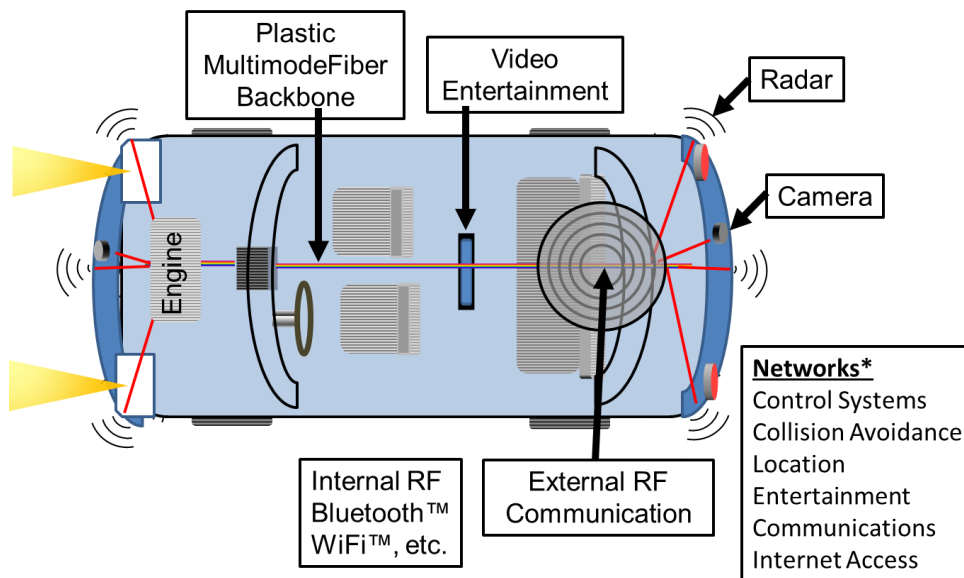

Figure OSC-8 Automobiles Have Multiple Networks to Measure Performance, Detect Obstacles, Control Operation, Deliver Entertainment to the Passengers, and Provide Communication to the “Cloud”

Note: As networks expand, there will be a move to reduce the use of copper and increase the use of low weight optical fiber interconnects with increased data rates and information density.

5.9.1. WIRELESS COMMUNICATION CHALLENGES

As vehicles strive to become more autonomous, more wireless capabilities will be employed to communicate with traffic networks, detect and monitor vehicles, pedestrians, animals, bicycles, obstructions, highway construction, and weather-related hazards, etc. This would include GPS and radar like detectors to monitor proximity, trajectory and speed of vehicles, pedestrians, animals, etc. Also, this information would be coupled with video and image recognition to determine expected actions of the objects. For the radar-like devices, different frequencies may be used to determine the density of objects. When the vehicle is traveling in inclement weather (e.g., fog, rain, snow, wind, flooding, etc.), multiple sensors will need to communicate with the central processor and internet, and protocols established on which monitors should be most “believed” in specific weather conditions. As auto vehicles become more autonomous, the demand for high-speed

communication, data, and entertainment media will increase. Within the vehicle, a Bluetooth and/or Wi-Fi like network will be used to communicate with portable devices including computers, phones, watches and possibly health monitors.

5.9.1.1. WIRELESS COMMUNICATION POTENTIAL SOLUTIONS

5G data rates with either massive MIMO or mmWave could support high data rate communication of maps, traffic flows and data from the vehicle to the manufacturer. Massive MIMO at frequencies <6 GHz has the potential for longer coverage range by a base station, while mmWave would have a shorter range of communication. Both approaches could use directional antennas with tracking of base station location to reduce the risk of spoofing and eavesdropping. This would require active phased array antennas with circuits and software to analyze incoming signals.

5.9.2. OPTICAL NETWORKS

With automobiles having more electronics and sensors for more autonomous driving vehicles, there is a need for high data rate and low weight communication networks. As a result, some automobiles are using plastic optical fiber communication to reduce weight and increase data rates. Over time, the data volumes are expected to increase as more sensors including cameras, radar, environmental sensors, and engine performance sensors are added to identify obstacles and improve automobile performance and comfort. To support this, data rates in fibers will increase from current 40 Gb/s to 100 Gb/s in 2023, as shown in Table OSC-13. A significant concern with plastic optical fiber is the practices and environment used for vehicle assembly and repair. Some commercial ICs are being developed to communicate over copper wire with the required data rates, so it is not clear which solution will prevail. It is assumed that current and developing technologies will be able to support these data rates in the required timeframe.

Free space optical may be used to provide information on proximity to other vehicles through lighting system modulation. In fact, the modulation of the brake lights could inform the vehicles behind whether it was just a “light touch” on the brake pedal, or if it were a hard break due to a dangerous situation. This was already implemented years ago by having different intensities for the brake lights, but that may not always work very well, depending on the environment conditions (fog, rain, snow, etc.) and distance between vehicles.

The biggest challenges will be to meet the environmental requirements for different applications that will require robust packages to manage shock and vibration, temperature extremes, etc. In addition, the fiber optic networks will need to meet significant cost challenges, which will require increasing levels of integration at the package and then at the device level. These increasing levels of integration can be supported by technologies developed to support Office LAN and data centers.

Table OSC-13 [Automotive Optical Interconnect Requirements](#)

5.9.2.1. OPTICAL NETWORKS POTENTIAL SOLUTIONS

Plastic optical fiber is the medium of choice and currently operates at data rates of 150 Mb/s for entertainment and is expected to increase to 1 Gb/s in 2020 and 10 Gb/s by 2025. For sensor and control communication in autonomous vehicles, data rates of 40 Gb/s are expected to increase to 100 Gb/s in 2023. To support higher data rates in the future, silicon photonic modules could be used with the plastic fiber; however, they would need to operate over a wider temperature range and at wavelengths compatible with the plastic fibers.

5.10. AEROSPACE

Fiber optics and wireless communication are being used in aircraft applications to reduce weight and increase bandwidth for a range of applications. Applications include entertainment, in flight networking, display systems and RF over fiber communication. In-flight entertainment can be transmitted over fiber to a “box” near the seats. For in-flight networking, data can be transmitted over fiber or free space optical to Wi-Fi stations or seat consoles that communicate with customer portable or mobile devices, as shown in Figure OSC-9. Furthermore, data from sensors, and potentially from control systems, can be communicated over fiber optics to the pilots. Fiber optics communication has several advantages over conventional copper wires including lower weight, electromagnetic interference immunity and smaller size.

High flying drone-like aircraft are also being developed to provide internet access with RF over large areas, as shown in Figure OSC-10, while the circling over an area needing access. This capability could be quite valuable to provide internet and mobile phone support for areas struck by disasters, earthquake, typhoons, hurricanes, floods, etc.

Free space optical interconnects are being proposed to provide communication, internet access, and entertainment to passengers in aircraft to reduce cost and avoid installing fiber in barriers [33, 34]. Free space optical interconnects are also proposed to support internal avionics communication [35] because the signals are secure from outside detection. These interconnects could use white LEDs, lasers, etc. and are immune from EMI, are low weight, low cost, and low power.

22 Technology Requirements

Currently, fiber optic communication is available in aircraft to operate at 10Gb/s, in multi-mode or single mode, and with wavelengths of 850 nm, 1310 nm, and 1550 nm. Table OSC-14. Fiber optic devices in aircraft must be able to operate in harsh environments, with thermal shock, mechanical shock, extreme temperatures (-40 to 125 °C), and devices must be protected from lightning strikes. It is anticipated that more applications will emerge related to increased use in control systems.

Table OSC-14 Aerospace Optical Interconnect Requirements (Preliminary)

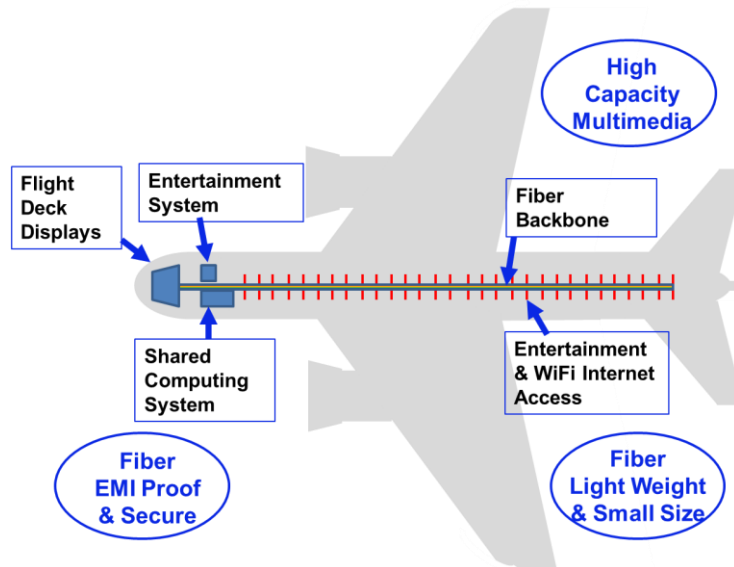

Figure OSC-9 Optical Interconnects Can Provide Interconnects for Internet Connectivity and Multi-Media Entertainment Distribution and in the Future Flight Deck with Computing Resources, Switches and Actuators, and Sensors in the Aircraft

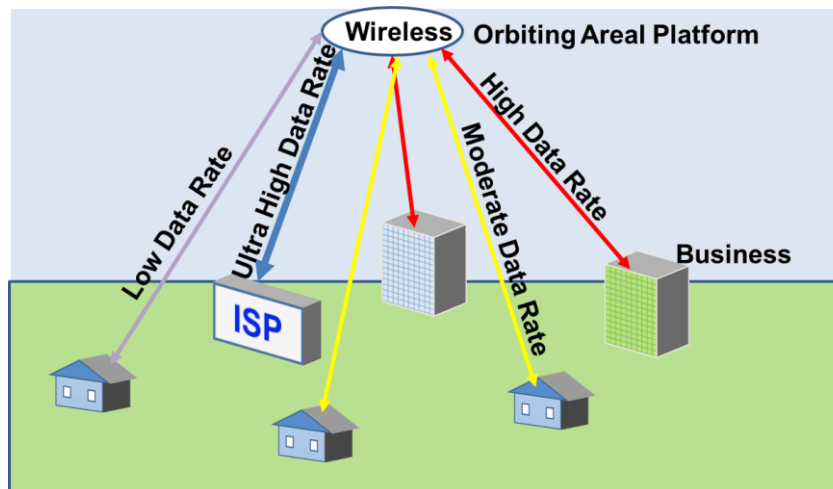

Figure OSC-10 Example of Wireless Flying Network Hub that Would Provide Internet Connectivity to Metropolitan or Rural Areas

Note: An aircraft would “orbit” or “hover” over a specific location out of commercial flight paths and provide services to businesses and consumers.

5.11.MEDICAL AND HEALTH DEVICES

Implanted (in patient) medical devices, which communicate with RF 175 kHz and 402-405 MHz [36], must be highly secure, consume low amounts of energy, and be highly reliable. They will need to communicate over RF with the internet,

(for example for homecare applications) or with other devices in the future, such as interconnected and integrated medical devices in a hospital environment (real time alarms on wearable devices held by medical doctors and nurses), or autonomous vehicles to identify a passenger medical emergency. On the other hand, they must not allow unauthorized access to the device that could jeopardize the patient, such as defibrillators activating pulses or withholding or overdosing insulin. These devices may have secure frequencies for program changes and other frequencies for transmittal of data or emergency assistance requests. These devices should be able to use capabilities developed for other applications.

Watch-like devices are being increasingly used to monitor heart rate and other functions during work or exercise and these devices can connect to a smart phone or other computer over Bluetooth to upload results. Over time more functions may be added to these devices. Also, monitors may be developed to identify over-exposure to UV, but it is not clear whether these will be passive or wireless.

Emergency medical response units are evaluating the communication of patient video (1.5-3 Gbps) to nearby hospital emergency personnel to enable them to assess patient condition and advise the emergency medical technicians (EMTs) on best treatment. It is also expected that higher resolution video (4K), which requires >10 Gbps will be implemented with more medical monitor information being transmitted to the hospital emergency personnel and this will require higher data rate wireless communication.

5.12. MISCELLANEOUS IOT DEVICES

IoT devices cover a wide range of products that need to communicate with the manufacturer or owner through their life. The most pervasive communication method will be through RF protocols. These devices would include appliances, tools, manufacturing equipment, and a wide variety of devices that include electronic control systems. They would connect to the internet through available network connections such as Wi-Fi, Bluetooth, LPWAN, etc. The need to communicate with the internet could include identifying a lack of activity by an elderly relative or detecting unexpected intrusions into a home. Again, security systems at the device level, and on the internet, are critical to prohibit unwanted monitoring of activity or enabling malicious activation by hackers or vandals. With low complexity monitors and/or actuators, the “base station” may need to have more sophisticated analysis of the origin (direction and distance) of the IoT device. Since many users do not activate security features, it may be necessary for the “base station” to autodetect the location signature and identify when the IoT device is installed.

A wide variety of LPWANs exist and serve special functions that have different coverage areas and data rate requirements as shown in Figure OSC-11.

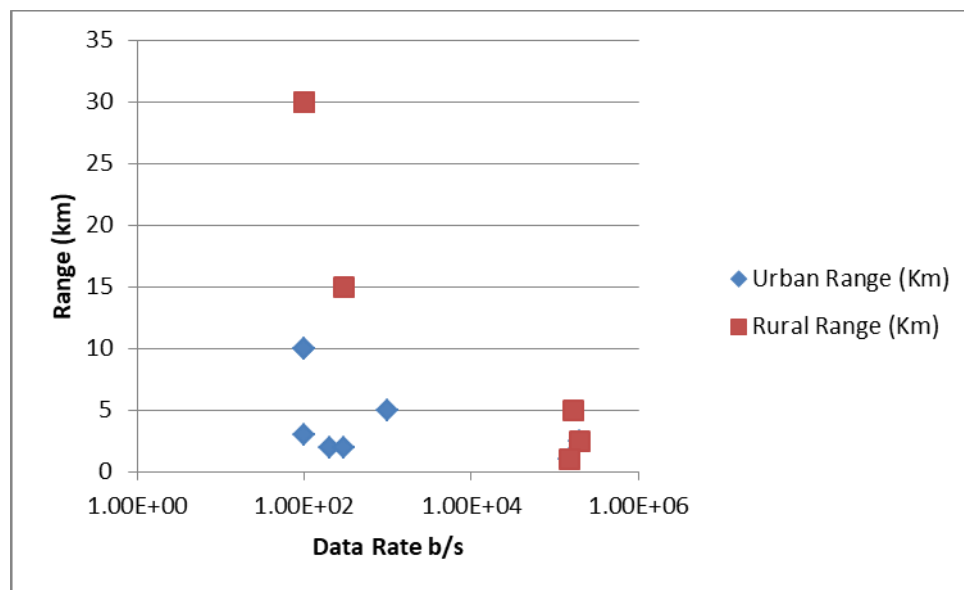

Figure OSC-11 Range of Select LPWAN Systems vs. Their Maximum Data Rates

Also, with the increasing proliferation of wireless devices, there are significant concerns that interference between RF signals from many wireless devices communicating in small areas will become a huge problem in the future. Some are proposing development of novel antennas and other schemes.

24 Integrated Circuit and Devices

With the wide range of applications and requirements for IoT devices, there will be many potential solutions. For battery powered IoT applications, the key challenge will be to reduce power consumption while meeting the communication data rate and range requirements. For high performance powered IoT applications, such as autonomous vehicles, etc., the challenge is meet the data rate and security requirements with continuous connectivity. Performance requirements for several wireless communication devices are shown in Table OSC-15.

Table OSC-15 [IoT Wireless Performance Requirements \(Battery\)](#)

5.12.1. IOT POTENTIAL SOLUTIONS

For the battery powered IoT devices, the potential solution is to develop more energy efficient communication protocols. For security, the IoT hub in addition to encryption may need to detect the location of the transmitting IoT device and verify that it is authorized. 5G also plans to support lower frequency (<1 GHz) communication with low data rate-low power devices over the same radio as higher data rate applications.

For powered high data rate applications, 5G communication with massive MIMO or mmWave would provide a data rate of 1 Gb/s. Furthermore, the directional communication used with massive MIMO and mmWave would reduce the likelihood of eavesdropping or spoofing. This could be further improved by including circuitry that continuously tracks the location of the IoT device and “hub” and detects anomalies.

6. INTEGRATED CIRCUIT AND DEVICES

Higher data rate lower power electronic integrated circuits and devices are needed to support both higher data rate RF communication and optical interconnects. For higher data rate RF employing pulse amplitude modulation (PAM) and other modulation techniques, lower power digital to analog converters (DAC), higher efficiency power amplifiers with high linearity and higher sample rate ADCs are needed for base stations and mobile devices. Furthermore, highly directional phase array antennas are needed to focus RF signals to the user instead of broadcasting in all directions. Optical interconnects also need higher data rate lower power electronic driver circuits and receiver circuits to support higher data rate optical transmission and receivers. Optical interconnects also are employing optical integrated circuits to increase data rates and potentially reduce power consumption. To continue increasing density of integration and reducing power per bit, lower power higher efficiency more compact optical sources and modulators are needed. In addition, more compact waveguides and multiplexers are needed to increase density without increasing crosstalk to reduce cost per bit communication. Optical receivers need high speed, highly efficient, high linearity compact optical detectors and amplifiers to support PAM and other modulation of signals in the fiber. For both photonics and high-speed RF, terahertz electronics may be needed to provide driver circuits that provide well shaped signals for precision required to support high levels of modulation.

6.1. RF INTEGRATED CIRCUITS AND DEVICES

The challenges for RF components include 1) achieving high performance energy efficient RF analog technology with high linearity that is compatible with CMOS based digital processing, and 2) components to meet 5G and 6G performance requirements. While all circuits contribute to loss of energy efficiency, the energy efficiency of PAs based on a given FET technology decreases with increasing mmWave frequencies; linearity can also be degraded.

6.1.1. INTEGRATED CIRCUITS FOR RF OR OPTICAL INTERCONNECTS

To increase data rates of communication with lower power and lower power, DAC and ADCs need to operate with higher sampling rates and lower power consumption. Also, serializer-deserializer (SERDES) circuits need to operate at higher frequencies with higher efficiency. To achieve higher data rates with improved energy efficiency in these circuits, devices need to operate with lower power at higher frequencies. This may require introduction of new device, gate, contact, or interconnect materials while decreasing circuit cost.

Recently, a 5nm integrated circuit technology was announced that demonstrated a transmitter test circuit that operated at 130 Gb/s data rates with PAM4 modulation and 0.97 pJ/bit energy consumption [37].

6.1.2. CMOS DEVICES

The 2020 roadmap technology plots reflect the RF and analog performance metrics needed to support the technology roadmap developed by the IRDS More Moore IFT in 2017. The RF-AMS performance metrics for CMOS devices have

been restricted to peak f_T (Figure OSC-12) and peak g_m (Figure OSC-13) and have been calibrated on recent averaged measured data in the 28 nm, 22 nm, and 16 nm nodes. The 2020 roadmap gives the above performance FoMs for n-channel FDSOI and double-gate FinFET high-performance devices obtained from technology computer aided design (TCAD)-based device modeling methods(a) [38]. These include hydrodynamic transport with thin silicon mobility physics, as well as the estimated resistive and capacitive device parasitics up to the first metal layer, which defines the terminals of a transistor cell in high-frequency analog circuit design. Compared to previous editions of the ITRS, the new f_T data provide a more realistic view of the projected high frequency performance of future MOSFET devices down to physical gate lengths of 7 nm. They indicate the degradation in f_T and g_m at gate lengths below 10 nm as a result of mobility degradation caused by surface scattering at the gate oxide interface, and due to the ever-thinner silicon body. As can be observed, the double gate of the FinFET results in higher transconductance but also higher capacitive parasitics compared to the single-gate FDSOI MOSFETs. Other MOSFET high-frequency figures of merit, such as f_{MAX} and NF_{MIN} , which are strongly dependent on the device layout used in particular circuit blocks have been removed from the CMOS section of the OSC tables. Note that the displayed f_T (Figure OSC-12) does not include the capacitive parasitics resulting from connecting the transistor cell to the passive devices in the upper metal layers of the back-end. The same was true for the f_{MAX} data included in ITRS editions through 2015. The introduction of new materials, and transistor and gate structures may change the f_T trend of sub 10 nm CMOS devices. Reduction of gate and contact resistance has been demonstrated to improve f_{Max} [39, 40], but not impact f_T .

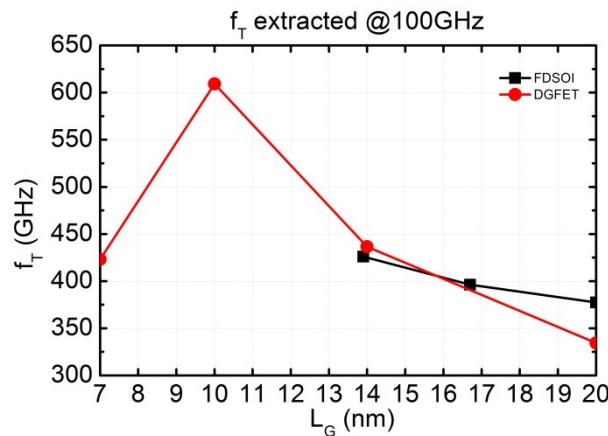

Figure OSC-12 CMOS Roadmap for Peak f_T vs. Physical Gate Length for FDSOI and Double-gate (FinFET) MOSFETs Based on Technology CAD⁴

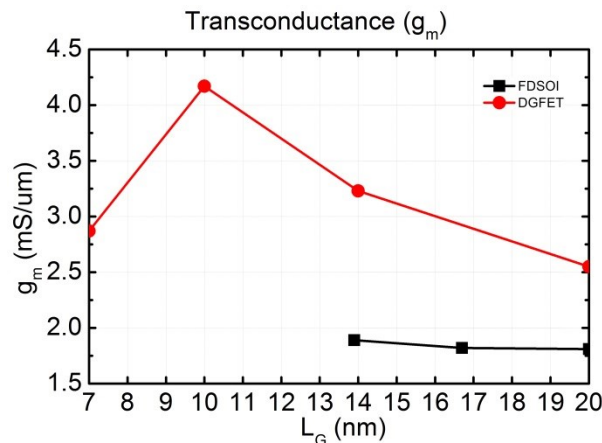

Figure OSC-13 CMOS Roadmap for Transconductance per Unit Gate Width, g_m , vs. Physical Gate Length for FDSOI and Double-gate (FinFET) MOSFETs Based on Technology CAD

Many of the materials-oriented and structural changes being invoked in the digital roadmap degrade or alter RF and analog device behavior. Complex tradeoffs in optimization for RF, HF, and AMS performance occur as different mechanisms emerge as limiting factors. Examples include series resistances at gate, source and drain, as well as parasitics from

⁴ TCAD simulations performed by Sorin Voinigescu at the University of Toronto.

interconnecting the transistors to other devices in a circuit that greatly affect the device impedances and the “loaded” figures of merit as measured at the upper metal levels. Fundamental changes of device structures, e.g., multiple-gates and silicon-on-insulator (SOI), to sustain continued digital performance and density improvements greatly alter RF and AMS characteristics. Such differences, along with the steady reduction in supply voltages, pose significant circuit design challenges and may drive the need to make dramatic changes to existing design structures.

6.1.2.1. CMOS POTENTIAL SOLUTIONS

Potential solutions for CMOS performance difficult challenges are covered in the More Moore Chapter.

6.1.3. GROUP IV BIPOLAR

The roadmap for SiGe heterojunction bipolar transistors (HBTs) and associated benchmark circuits at mm-wave frequencies has been based since 2013 on a seamless set of TCAD device simulation tools in order to obtain consistent compact model parameters for the complete transistor structure used in the respective circuit simulations. All known transport, structural parasitics up to metal 1 (i.e. transistor cell terminals) and temperature effects have been included in the results [41] and calibrated based on experimental data. Furthermore, the TCAD tools and those parameters that cannot be obtained by TCAD have been calibrated on existing prototyping process technologies. The data (including the minimum emitter width W_E , and all electrical performance parameters such as f_T , BV_{CEO} , BV_{CBO} , J_C at peak f_T , NF_{MIN} , MAG etc.) in the 2015 Technology Requirements Tables for high-speed NPN transistors, have been shifted by one-year, as shown in Table OSC-16. Performance plateaus have been assumed to last four years and are linked to applications and the foregoing system drivers. It has been assumed that at least two foundries offer the technology of the respective node for product prototyping are presented. The benchmark circuits for LNA, PA, VCO, and current-mode-logic-based (CML) ring-oscillator (RO) have been manually optimized for each technology node and a variety of commercially relevant frequencies. The most recent result for a prototyping process [42] corresponds closely to the performance predicted for node N3.

Table OSC-16 [RF and Analog Mixed-Signal Bipolar Technology Requirements](#)

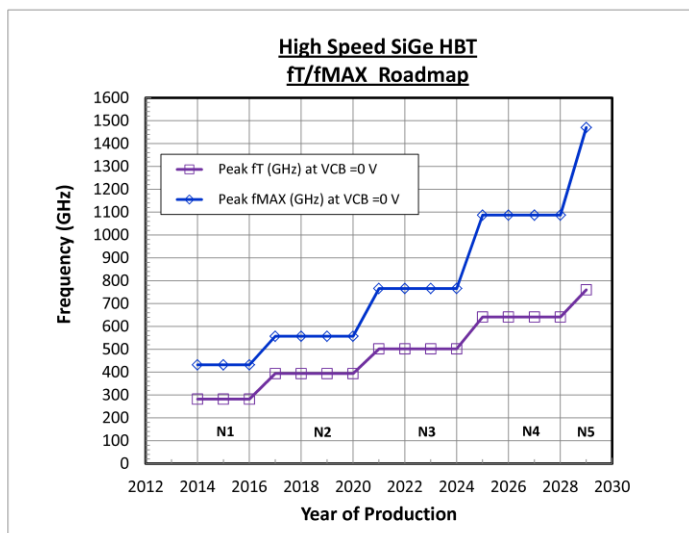

Figure OSC-14 High Speed SiGe HBT f_T and f_{MAX} Roadmap vs. Year of Production

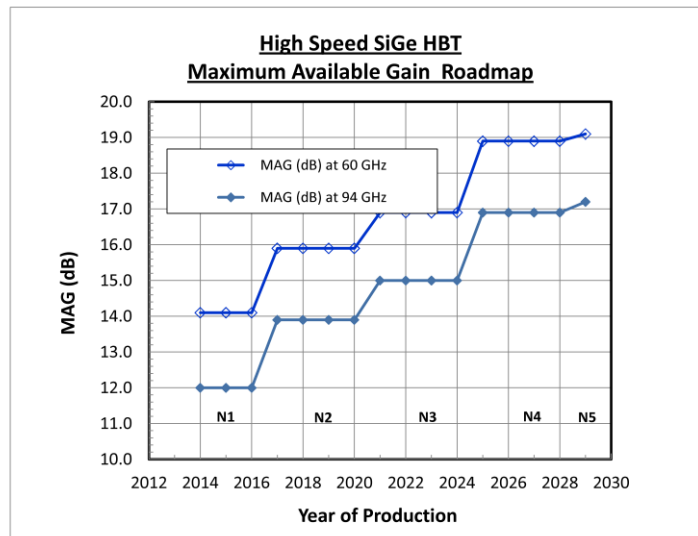

Figure OSC-15 High Speed SiGe HBT Maximum Gain Roadmap vs. Year of Production

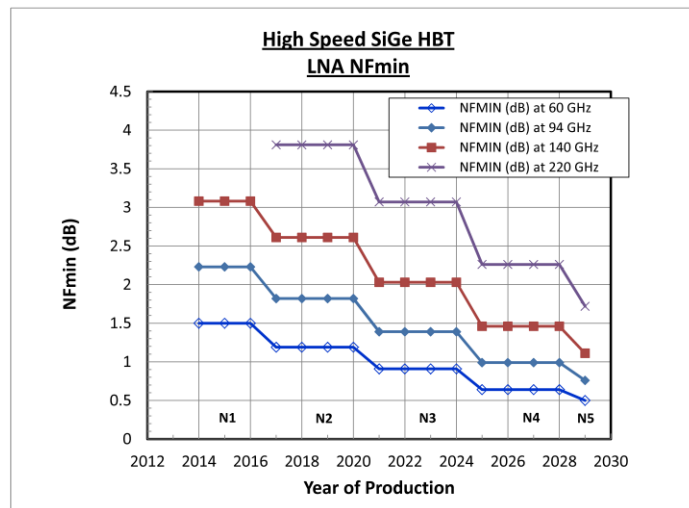

Figure OSC-16 HBT Minimum Noise Figure with Ideal Reactive Components vs. Year of Production

Even though it is a challenge for the HS-NPN to increase the unity current gain cut-off frequency f_T by more aggressive vertical profiles, it is less of a challenge to achieve $f_{MAX} > f_T$. What is unclear today is, how large the ratio f_{MAX}/f_T needs to be for future circuit applications. That is, the challenge is to determine what this ratio should be by using the “plateau technologies” for the next roadmap and appropriate benchmark circuits. Since lateral scaling requirements for HBTs are significantly relaxed compared with those for MOSFETs, vertical profile fabrication under the constraints of overall process integration appears to be the bigger challenge. The reduction of imperfections and the increase of current carrying capability of the emitter and collector contact metallization are further challenges that need to be met by process engineers on the way to achieving the physical limits of this and any other technology[41].

6.1.3.1. GROUP IV BIPOLAR/BICMOS POTENTIAL SOLUTIONS

For the group IV bipolar devices, a number of potential solutions are under evaluation[43] including improving process steps and new device architectures as shown in Figure OSC-17.

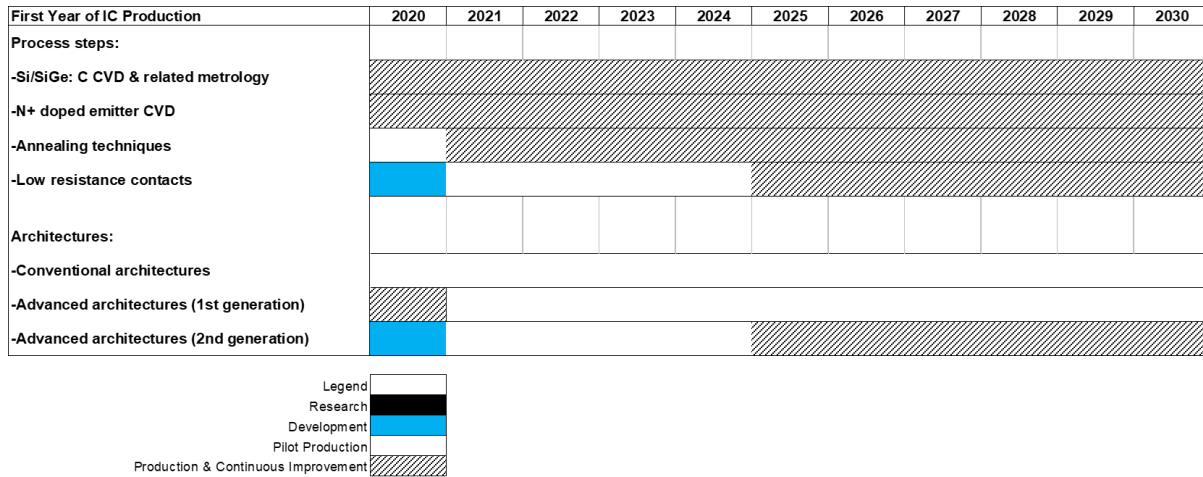

Figure OSC-17 High-Speed SiGe BiCMOS Potential Solutions

6.1.4. III-V FET & BIPOLAR

We have assumed “production” implies that at least one company offers products with “data sheets” or that the technology is available for custom designs from one or more companies as a foundry service. The productions dates for all technologies have been shifted by one year later. The ‘pull’ for these technologies partly drives this shift. The III-V roadmap truncates at the following expected ends of scaling: GaAs pseudomorphic high electron mobility transistor (PHEMT) in 2015, GaAs power metamorphic high electron mobility transistor (MHEMT) in 2020, and InP power high electron mobility transistor (HEMT) in 2016. However, it is expected that low noise GaAs MHEMT and InP HEMT, InP HBT, and GaN HEMT will continue with physical scaling. The 2012 Update, as in the past, has only D-mode field effect transistor (FETs). E-mode devices are in the 2013 and 2014 updated roadmaps. The FoMs depend on technology and will include: f_T , f_{MAX} , g_m , and V_{BD} ; power, gain, and efficiency at 10, 24, 60, 94, 140, and 220 GHz; NF_{MIN} and G_A at 10, 24, 60, and 94 GHz; LNA NF and G_A at 140 and 220 GHz, as shown in Figures OSC-18–OSC-21 and Table OSC-17. As mentioned previously, RF and AMS front-end components are a growing part of the semiconductor industry. However, this has divided the III-V technology landscape into two groups, one dominated by the large volume consumer market and the other dominated by low volume specialty markets. Within the III-V technology landscape, the large volume consumer driven market is best represented by GaAs HBT power amplifiers for cellular communications. Here the dominant driving force has become cost, and there is only a marginal device performance improvement from year to year. The low volume specialty markets to which InP HEMT, InP HBT, and GaN HEMT presently belong also suffer from the slow pace of the slow transition to mass production due to low product volumes. Many of these technologies are driven by non-commercial needs and experience sudden leaps in performance only when government funding becomes available. For these reasons, the value of the III-V roadmap has been called into question. This sub-group seeks greater industry participation and immediate input concerning the III-V technology roadmap and priorities.

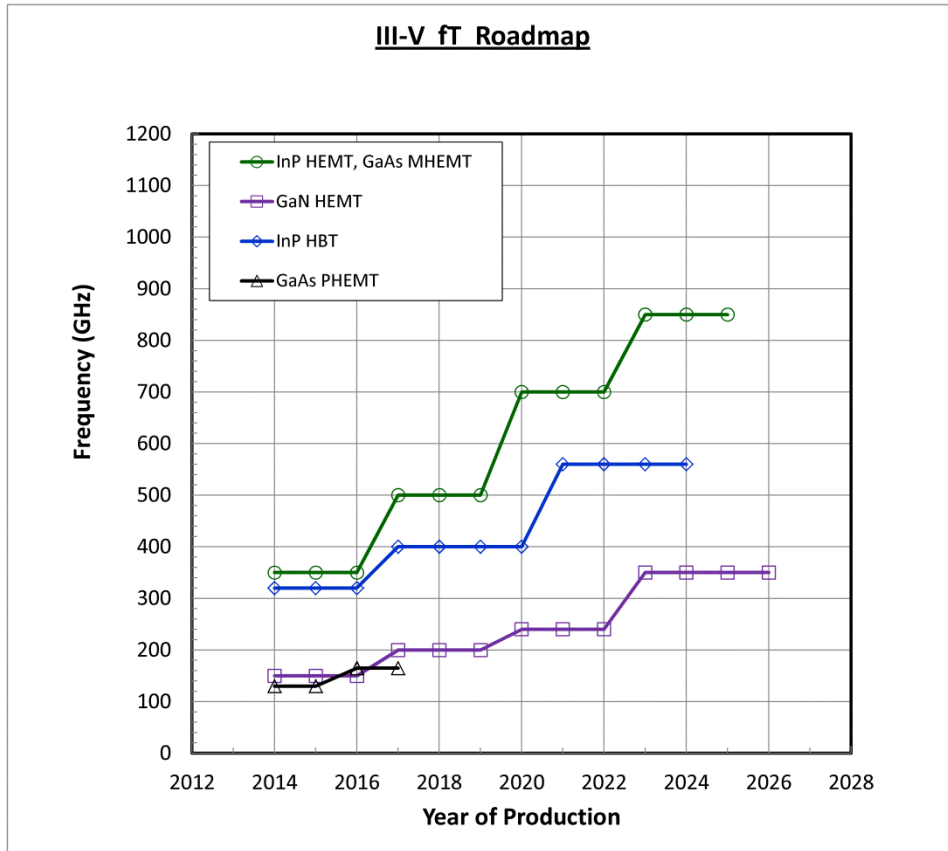

Figure OSC-18 III-V Roadmap for fT

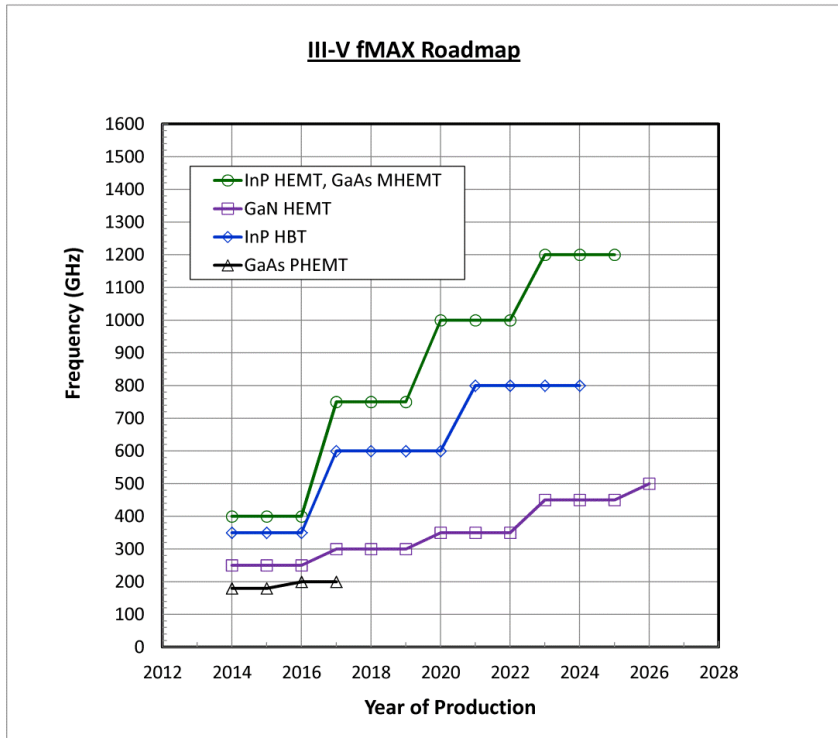

Figure OSC-19 III-V Roadmap for fMAX

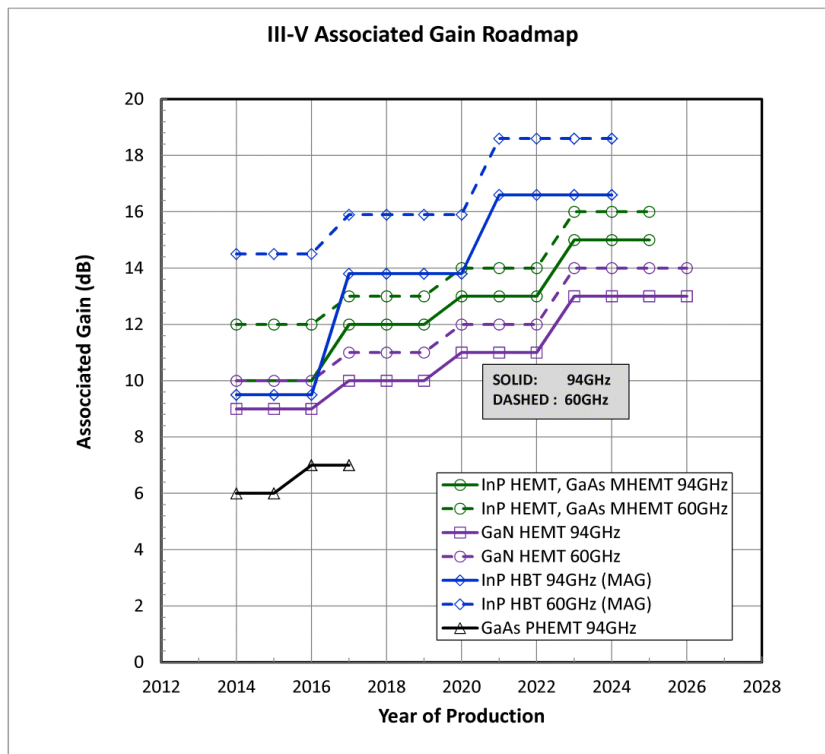

Figure OSC-20 III-V Roadmap for Associated Gain

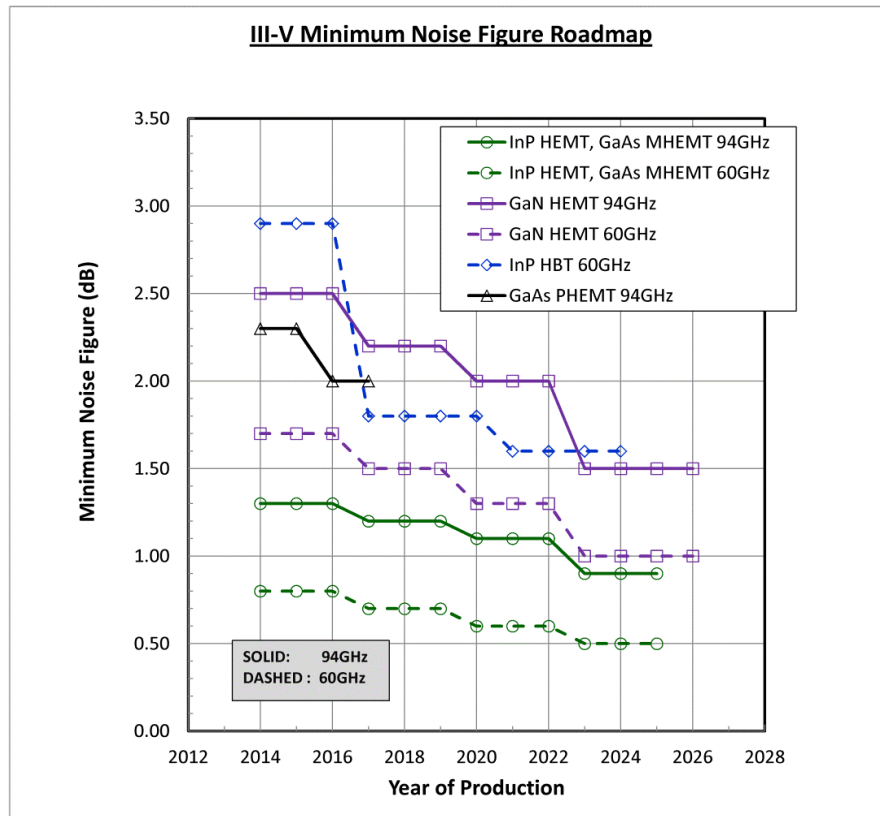

Figure OSC-21 III-V Minimum Noise Figure Roadmap

Table OSC-17 Group III-V Compound Semiconductor FET and Bipolar Transistors Technology Requirements

The unique challenges for III-V devices are yield (manufacturability), substrate size, thermal management, integration density, dielectric loading, and reliability under high fields. Challenges common with Si-based circuits include improving efficiency and linearity/dynamic range, particularly for power amplifiers. A major challenge is increasing the functionality of power amplifiers in terms of operating frequency and modulation schemes while simultaneously meeting increasingly stringent linearity and efficiency requirements at the same or lower cost.

6.1.4.1. GROUP III-V COMPOUND SEMICONDUCTORS CONSISTING OF ELEMENTS FROM GROUPS III AND V [BOTH BIPOLAR AND FIELD EFFECT TRANSISTORS (FET)]

For Group III-V devices, potential solutions under evaluation include improved thermal management, new epitaxy and substrates, device scaling technologies, heterogeneous integration on silicon, high throughput e-beam lithography (FETs only), and multilevel interconnects, as shown in Figure OSC-22. More detailed descriptions of these can be found in [43, 44].

First Year of IC Production - Manufacturing/Technology Readiness	2022	2023	2024	2025	2026	2027	2028	2029	2030	
III-V Semiconductors										
Thermal Management	Research		Development			Production & Continuous Improvement				
Enhancement mode devices	Production & Continuous Improvement									
Epitaxy and Substrates	Production & Continuous Improvement									
GaN on Silicon Carbide	Production & Continuous Improvement									
Larger diameter substrates	Production & Continuous Improvement									
200 mm GaAs	Production & Continuous Improvement									
150mm InP	Production & Continuous Improvement									
150mm SiC	Production & Continuous Improvement									
100mm GaN	Production & Continuous Improvement									
Lower defect density SiC substrates	Production & Continuous Improvement									
Device Scaling (both FET and HBT)	Production & Continuous Improvement									
Ohmic Contact Resistance Reduction	Research		Development			Production & Continuous Improvement				
Junction Control (Dimension, Epitaxy,	Research		Development			Production & Continuous Improvement				
Heterogeneous Integration of III-Vs on Silicon Substrates	Production & Continuous Improvement									
Multi-level interconnect/high level	Production & Continuous Improvement									
Uniformity, Reproducibility and Yield	Production & Continuous Improvement									

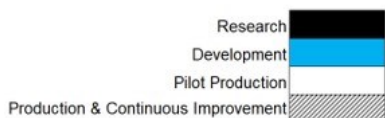

Figure OSC-22 Group III-V Compound Semiconductors Potential Solutions

6.1.5.ANTENNAS TO SUPPORT 5G COMMUNICATION

Both mMIMO and mmWave based communications are proposing to use highly directionally focused beams, to and from the user, to increase range while using less power.

The potential solution is to employ phased array antennas where signals of multiple small antennas are shifted to constructively reinforce in the desired direction and destructively interfere in other directions. Several groups have demonstrated these on silicon substrates while others are fabricating them on laminate substrates. The challenge is to have energy and component efficient operation to meet cost and energy objectives. With phased array antennas, the signals must be timed to constructively interfere and change direction as the communication direction changes. Base stations may employ more sophisticated control, but mobile smart phones need simple, low cost, low power techniques.

For mobile phones, the cell phone would need to have multiple antennas to receive and transmit information and each antenna would need to have a PA and an ADC and DAC [27], which would consume considerable power operating with high precision at high frequencies. In the transmit mode, the antenna array would operate as an active phased array to focus transmission toward the base station. To overcome the high operating power of the high precision DAC/ADCs, use of hybrid analog/digital preprocessing [28, 29] or lower precision DAC/ADCs (1bit)[27, 29, 30] has been proposed. To compensate for potential blockages[31], multiple antennas would need to be integrated into the cell phone to be connected with multiple base stations.[32]

Since the mmWave focusing antenna has multiple elements transmitting signals with different phases, the antenna array would need to be fabricated on a smooth substrate with low k dielectric and precise control of feature size shape, and separation. For 28 GHz the ¼ wavelength is ~0.25 cm and at 72 GHz the ¼ wavelength is ~0.1 cm, so distortions of some fraction of this could cause problems with beam forming. Substrates with variation in surface height could result in phases being shifted resulting in changes in the direction of the focused beam. Similarly, the phased array substrate must not warp with temperature or the beam focus and direction could shift with operating temperature. Thus, thin substrates with high modulus and low dielectric constant will be needed as frequencies increase to low mm wave range.

Since the number of antennas in a mobile phone continues to increase, a switchable antenna has been proposed that could switch between diversity mode and MIMO mode [45]. Also, an antenna has been proposed that could receive 4G and 5G (3.5 GHz MIMO) [46].

6.1.6. TERAHERTZ ELECTRONICS

Radiation in the terahertz (THz) range, which is non-ionizing and enables imaging through opaque material layers, is of potential relevance for a large variety of applications [47, 48] such as: non-destructive material inspection, medical diagnostics, transportation, security screening, industrial automation, extremely high data-rate communications, and space exploration. Unfortunately, THz signal power generation at room temperature (RT) by either electronic or optical components presently suffers from poor device performance. Particularly, between 0.5 and 10 THz the output power of both optics and electronics drops to very low levels. Similarly, signal detection in this THz gap is plagued by high loss in the frequency conversion process. The realization and deployment of future, partially mobile, RT-integrated THz systems will be driven mainly by cost, form-factor, signal power, and energy-efficiency. These requirements and the much easier integration with digital signal processing circuitry favor electronics-based systems over purely optical systems.

Semiconductor technologies with transistor cut-off frequencies far beyond 300 GHz (the lower limit of the so-called THz gap) have been surveyed in [41, 43, 44, 48, 49]. The performance of various circuit blocks based on present and future (expected) HBT technology have also been assessed [44 and 50]. One of the results of the European DOTSEVEN project was the first all-silicon computer tomograph operating in the THz gap using SiGe HBTs for radiation and Si CMOS based sensors. Monolithic ICs have also been demonstrated with InP High Electron Mobility Transistors (HEMT) [51,52].

To enable precise shaping and decoding of modulated signals, THz electronics may be needed to provide the drivers, amplifiers and detectors for both photonics and RF. With 5G pursuing both <6 GHz massive MIMO and mmWave RF, technologies beyond 5G may require 100GHz+ operating frequencies. Furthermore, photonics is increasing data rates in single fibers through a use of multiple wavelengths and modulation of different photonic properties. In either case, electronics is needed to process the data stream and feed data to the CPUs. THz electronics will be needed in the future to support these high communication data rates.

A major challenge of THz electronics is the loss of output power with frequency. Thus, obtaining gain and product-level output power will require transistor cut-off frequencies well beyond 1 THz. Other challenges are the development of suitable low-cost THz packages as well as measurement techniques and equipment for standard device and circuit characterization. Therefore, opening up the THz gap for electronic applications benefiting society will be require innovations at the device, material, and system architecture level as well as in circuit design techniques and modeling.

6.2. PHOTONIC INTEGRATED CIRCUITS AND DEVICES

Near-term challenges are to 1) Increase the operating frequency and density of optical transceivers while reducing their power and cost, and 2) develop router/switch package integrated photonic interconnects for data centers. Long-term challenges include 1) processing information in the optical domain, and 2) develop methods for communication between systems with different wavelengths, polarizations, modulations.

6.2.1. PHOTONIC MONOLITHIC HETEROGENEOUS INTEGRATED CIRCUITS (PIC)

Recently, optical monolithic heterogeneous integrated circuits have been introduced into the market by multiple suppliers. Currently, most of these circuits have separate transmitter and receiver circuits.

Some of these transmitter circuits have the lasers integrated with the modulators, while some of these have the laser packaged separately from the modulators. In most cases, the modulators and waveguides are single crystal silicon on insulators. Multiple suppliers are employing Mach Zehnder modulators, while more compact ring modulators are being evaluated in research. Since ring modulator wavelength is sensitive to temperature, some have integrated heating elements to control the optimal wavelength, which increases power consumption that must be managed. Many of these transmitter circuits employ multiple wavelengths that either are transmitted over individual fibers or multiplexed into a single fiber. Mach Zehnders and the multiplexers currently use silicon waveguides that must gently bend to insure that optical losses are minimal, which causes the circuits to be relatively large.

Optical receiver circuits must separate wavelengths and transmit these to SiGe photodetectors. The output of the photodetector is amplified and transmitted to a DAC for digital processing with a SERDES.

There is a significant demand in the industry to integrate photonic I/O in the package with networking switches to reduce switch power consumption. This introduces significant new challenges to integrate the photonic I/O with a high heat generating IC and develop high density fiber connectors that are “pluggable” to the package photonics. There is significant

discussion over whether the laser should be packaged separately or integrated on the silicon photonics due to the high temperatures generated by the switching IC, which would cause thermal drift of wavelength and reduce the life of the laser. Even if the laser is mounted separately, the modulators must have a low temperature coefficient. Also, the switch will need to support >256 I/O being sent or received from servers, which is a significant challenge.

In the future, reducing cost and increasing data rates while reducing power consumption will drive development of more compact and energy efficient technologies. Data rates will be increased by employing different modulation techniques including PAM, polarization modulation, and other techniques. This will place even more challenging requirements on the optical integrated circuits. Reducing cost may be achieved by increasing integration of other optical and electrical components onto the PIC and development of more compact optical devices (lasers, modulators, MUXes, waveguides, and other structures). Development of more energy efficient lasers and detector amplifiers and supporting electronic components is crucial.

6.2.2. LOW POWER HIGH OUTPUT LASERS

To reduce the power consumed in communication, there is a need to increase the efficiency of lasers in converting electrical energy to photons. VCSEL and edge emitting lasers are used for different applications and may be competing in some applications as silicon photonics strives to reduce cost while increasing data rates.

Although VCSELs are more energy efficient than edge emitting lasers, the power to communicate at higher data rates will increase, so more efficient top emitting lasers are needed in the future. To support high volume manufacturing, quantum dot laser VCSELs fabricated epitaxially on silicon 001 [53] with p-doping [54] have been demonstrated with high stability over a wide temperature range (thermal stability).

An emerging technique to increase photonic light source energy dissipation is to introduce nanostructures that increase energy density. This has been used to demonstrate electrically pumped lasers with lasing thresholds of 287 nA at 150 K [55] that is 1000× less than earlier electrically pumped nanocavity lasers. Furthermore, these structures have been used to demonstrate directly modulated photonic crystal nanocavity light-emitting diode (LED) with 10 GHz modulation speed and less than 1 fJ per bit energy of operation [56]. These demonstrate that nanostructured nanocavity lasers and LEDs have the potential to provide more energy efficient photonic sources for optical interconnects; however, the lasers must operate with high energy efficiency above room temperature.

The ability of lasers to controllably emit specific modes could enable compact optical circuits with new functionality. Single mode ring laser [57] utilizing the parity-time symmetry breaking has been demonstrated that is intrinsically stable for a specific mode rather than having multiple competing modes. This capability could enable compact lasers and resonators that could enable on chip Input/Output with single modes of light. Furthermore, it is possible this principle could be used to control at will specific single modes that are emitted by the laser.

6.2.3. HIGH DENSITY LOW POWER MODULATORS

For optical interconnects to meet future requirements, all supporting devices must operate with higher performance, lower energy consumption, higher optical efficiency, and have lower cost. Electro-Optic Modulators (EOM) can modulate the amplitude, phase, frequency, or polarization of the light; however, these devices must become more compact, operate with lower power consumption.

Initial Mach-Zehnder interferometers were large and consumed significant power in modulating the light; however, newer compact devices have been demonstrated that require lower power and some may enable integration on substrates with lasers. A 100 μm long silicon p-i-n diode Mach-Zehnder [58] has been demonstrated to modulate phase with 5pJ/bit.

A silicon lateral p-i-n ring diode less than 20 μm diameter has been demonstrated to modulate wavelength [59] and could be used for wavelength division multiplexing (WDM). Incorporation of a photonic crystal into the silicon p-i-n diode structure [60] reduced power consumption with wavelength modulation. A reverse biased silicon p-n ring diode structure [61] was able to operate at 11 GHz with energy consumption of 50 fJ/bit and a device area of ~1000 μm². A GaAs photonic crystal cavity EOM [62] has been demonstrated that has the potential for sub fJ/bit energy consumption in the GHz frequency range.

Although these devices have dramatically reduced EOM size and energy consumption, modeling indicates the possibility for further improvement in energy consumption [63].

6.2.3.1. ELECTRO ABSORPTION MODULATORS

The most important issues for electroabsorption modulators are to have a high on/off ratio, be compact, have a high operating frequency, low optical loss, and low energy dissipation.

6.2.3.1.1. BULK SEMICONDUCTOR FRANZ-KELDYSH EFFECT (III-V, Ge)

When a high electric field is applied to a semiconductor, the absorption edge of the material can shift and absorption can increase. Application of an electric field causes a gradient in the valence and conduction bands of semiconductors and which increases tunneling and an overlap of wave functions that produces an increase of optical absorption near the bandgap. Thus, application of an electric field increases optical absorption near the bandgap. This must be done in a thin film to achieve significant tunneling between bands. This effect is most pronounced in direct bandgap semiconductors (i.e. III-V).

A SiGe modulator on SOI has been demonstrated to operate at 28 Gb/s with 5.9 dB on/off ratio at 3.0V bias with a 50 μm long active region[64]. Work is needed to reduce the size, reduce voltage and reduce energy dissipation.

6.2.3.1.2. PLASMONIC MODULATOR

Recently, a plasmonic Mach Zehnder modulator that fits into a 10 μm silicon waveguide has been demonstrated that operates to 70 GHz and consumes 25 fJ/bit [65]. A plasmon assisted ring modulator was demonstrated that operated $\gg 100$ GHz with 2.5 dB loss, 12 fJ/bit, and low thermal drift [66]. An in-phase/quadrature (IQ) electro-optic modulator fabricated with plasmonic Mach Zehnders has been demonstrated to operate at 50 Gb/s with an energy consumption of 0.07 fJ/bit and at 400 Gb/s with an energy consumption of 2 fJ/bit [67].

6.2.3.1.3. STARK EFFECT

The Stark effect in semiconductor quantum wells occurs when coupled electron-hole pairs (Excitons) are trapped in quantum wells. This produces increased optical absorption near the bandgap of the quantum well bandgap. Application of an electric field reduces the overlap of the electron and hole wave functions and thus reduces the optical absorption near the bandgap. Thus, the Stark effect electro-absorption reduces light transmission without electric field and increases transmission with electric field. This effect has been demonstrated in Ge quantum wells [68], a 90 μm long Ge-SiGe quantum well modulator has been demonstrated to operate at 23 GHz with an on/off ratio of 9 dB and energy dissipation of 108 fJ/bit with a swing voltage of 1 V between 3 V and 4 V [69].

Further work should be done to increase the on/off ratio, reduce optical losses, reduce energy dissipation and determine the temperature dependence of modulation.

6.2.3.1.4. WANNIER-STARK LOCALIZATION

The Wannier-Stark localization occurs in semiconductors with minibands, such as superlattices i.e., coupled quantum wells, when the applied electric field is sufficiently large to decouple the quantum wells, i.e., breaks down the sub-bands and produces localized states in quantum wells, which in turn causes a strong blue shift to the absorption. When this happens, the photo-absorption is sharply reduced, which was theoretically [70] and experimentally [71, 72] demonstrated in 1988. It was experimentally demonstrated for the 1.55 μm wavelength range in 1991 in InGaAs/InAlAs superlattices, with an 11 dB extinction ratio, by applying a 0.7 V voltage to a 100 μm long waveguide [73]. This concept is not specific to any materials system, and can be used with any superlattices, including group-IV superlattices [74].

6.2.4. COMPACT MULTIPLEX (MUX)/DEMULTIPLEXERS (DEMUX)

MUXes merge multiple wavelengths while DeMUXes separate wavelengths into separate waveguides or fibers. Currently, these devices must make gradual bends in the waveguide to maintain total internal reflection and minimize losses. As more wavelengths are merged into waveguides or fibers (i.e., 64, 128, 256, etc.) the size of these can become very large, so technologies are needed to enable low loss compact merging and splitting capabilities. Two potential approaches to this are aperiodic nanophotonic structures and plasmonic structures, which have the potential to compact wavelength merging functions to μm scale and thus significantly reduce the size of MUX and DeMUX devices. In particular, materials with optical index having a low thermal sensitivity will be required.

6.2.4.1. PLASMONIC STRUCTURES

There is a significant need for technologies that can compactly change the direction of light propagation and focus light on small features. Plasmonic structures have properties that could enable potential solutions to these issues [75]. Specific materials have surface electronic resonances that interact with photons and confine them in small waveguides (<100 nm)[75] and cause them to change directions in short distances [76]. An issue is that the plasmons absorb energy from the light at their resonance, so the interaction lengths must be short. Recently, it has been proposed to use electrical pumping to reduce losses in hybrid plasmonic waveguides [77]. On the other hand, the plasmons are relatively insensitive to temperature changes, so they should be stable with temperature.

Plasmonic structures have been predicted to enhance optical absorption in photodetectors [78], confine light in sub-wavelength waveguides, and redirect light to new directions within 1 μm . It has been predicted that novel structures may be able to significantly reduce losses in plasmonic waveguides [79]. The ability to concentrate light to very small photodetectors could enable very fast photodetectors with high signal to noise ratio [80]. It was proposed that plasmonics could be employed to produce energy efficient compact electromodulators [81] and an active plasmonic modulator has demonstrated 10 Gb/s data rates with low energy [82]. Recently a 10 μm plasmonic modulator has operated at 70 GHz while consuming only 25 fJ/bit [83].

For future logic, a plasmonic absorber-amplifier [84] has been designed that could amplify specific wavelengths in a WDM application while absorbing other wavelengths, purify the phase of a non-phase pure source according to a phase-pure reference source, modulate an optical signal driven by an input gate optical signal with amplification, or provide directional optical isolation. Thus, plasmonics may not only have the potential for enabling compact dense photonic routing and modulation but may also potentially enable photonic logic functions.

6.2.4.2. APERIODIC NANOPHOTONIC STRUCTURES

Future computing and communication systems require miniaturized components integrated into complex system for advanced information processing functionalities. The use of aperiodic and dynamic photonic structures may provide solutions to meet such requirements. In particular, the use of aperiodic structures enables the constructing of high-density compact routing in waveguides with single wavelength scales. The use of dynamic structures potentially provides reconfigurability, as well as functionalities that are not available in static systems such as dynamic non-reciprocity.

Significant advances have been made in understanding the interactions of photons with aperiodic photonic structures. A particularly important advancement is the developments of ultra-fast numerical algorithms that enable fast simulations and optimization of nanophotonic structures [85]. With these algorithms it is possible to scan through very large ensemble of nanophotonic structures to develop a statistical understanding of these components in the presence of structural statistical variations, and to design highly functional and yet compact components for mode division multiplexing and wavelength division multiplexing systems.

A 2.8 by 2.8 μm inverse designed silicon aperiodic structure has successfully separated 1300 nm and 1550 nm light into two output waveguides with an insertion loss of $\sim 2\text{dB}$ and crosstalk of -11dB [86]. While is not adequate for a CWDM multiplex system, it may offer promise for future more compact deMUX structures.

For aperiodic nanophotonic structures, the temperature dependence of the structures and potential optical losses must be determined. Also, these structures would need to be encapsulated with a robust material of a different refractive index to protect the structures from contamination and environmental interferences.

6.2.5. WAVEGUIDES

To increase density of components on silicon photonics, waveguides need to be fabricated in higher density with low crosstalk and with low optical losses. Recent research is working to address these issues. Recent work has demonstrated that introducing a dielectric metamaterial cladding around a silicon waveguide can reduce the evanescent wave loss by 30X and reduce losses at bends by 3X [87]. Introducing a half-wavelength pitch superlattice waveguide has been demonstrated to reduce crosstalk to $<30\text{ dB}$ [88]. Plasmonic metal waveguides have demonstrated the ability to confine and guide light; however, there are significant losses. There are proposals and modeling indicating that graphene-BN 2D heterostructures [89] or 2D dichalcogenide heterostructures [90] can confine light with losses.

6.2.6. HIGH SPEED, HIGH DENSITY PHOTODETECTORS

A significant challenge for optical detectors is to increase operating frequency to support higher data rates. A limiting factor is the RC time constant of the photodetector. The most logical solution is to reduce the detector size that reduces junction capacitance, but this can increase resistance and may reduce coupling efficiency to the light from the waveguide. Effort would be needed to reduce the junction and contact resistance for the smaller photodetectors. If the detector intercepts less light from the waveguide, the amplifier will need to have higher gain that will potentially reduce the signal to noise ratio. The best solution to this is to develop techniques to effectively couple light from the waveguide into the detector. Possible solutions include using plasmonic structures above the photodetectors to focus light into the detector. Another option is to passive periodic or aperiodic nanophotonic structures to focus light onto the photodetector. The temperature dependence of the potential solutions needs to be understood, to design the optimal solution. This would give the amplifier a larger signal to amplify and reduce signal to noise.

6.2.7. SINGLE MODE CONNECTORS

The ability to connect a single mode fiber to others or devices or waveguides on package or boards is critical to enabling high-performance longer-range networks in data centers. Recent work has focused on connectors that expand the beam and then refocus on the next optical element. With the drive to integrate photonic I/O into the network switch package, this will require significant work to enable high density pluggable photonic connectors.

6.2.8. OPTICALLY BASED SWITCHING AND ROUTING

Currently, optical signals are redirected by electrical routers where the light must be converted to electrical signals that are routed to different laser-fibers. This significant latency can be added to the transmission of optical signals that go through multiple routers. New technologies are needed to enable optically based switching and routing that does not require the optical-electrical-optical conversion. Hybrid electrical/optical (E/O) routing capabilities have been demonstrated using both MEMS [5–8] and E/O switches including Mach-Zehnder interferometers [10] and ring modulators [11].

To support all optical switching, new materials and device structures are needed to enable this dynamic optically controlled routing capability. Potential schemes for driving may include having one wavelength dedicated to establishing the routing path, while others would transmit the data. Optically based switching has been demonstrated in III-V [91, 92] and in silicon-based structures [93], and amorphous silicon-based structures [12] with micro-ring resonators, where sending a higher than bandgap photon pulse excites carriers and temporarily changes the refractive index of the material. These are examples of devices that could be integrated to enable optically based switching and routing functions. More research is needed to identify new technologies that offer greater flexibility in optically based switching and routing with lower power consumption.

6.2.9. OPTICALLY BASED LOGIC

If all optical networks are to be viable, optically based logic will be needed to identify signal stream routing conflicts and determine the correct routing alternative. A number of optical logic devices and functions have been proposed that require local nonlinearity of optical properties [94]. It is proposed that branched waveguides with local nonlinear optical materials could function as AND or OR functions [95]. All optical logic based on optical polarization switches has also been proposed [93] that would require polarizing switches that require optically activated polarizers [94]. Using cross gain modulation and cross phase modulation in semiconductor devices, many logic functions have been demonstrated including AND, OR, XOR, NOR and XNOR [87], but they are limited to ~10 Gb/s. Several all-optical logic concepts have been proposed and some demonstrated, but their speed and efficiency would need to improve to support future all optical networks. A critical need for all optical high-speed logic is materials that can change optical properties at >100 GHz speed upon exposure to optical signals.

6.3. OPTICAL TEST

Development of new and developing optical devices and integrated circuits needs test to measure the performance of optical interconnect devices and systems as shown in Table OSC-18.

Table OSC-18 [Optical Interconnect Test Capability Requirements](#)

7. CROSS TEAMS

7.1. SYSTEMS AND ARCHITECTURE

OSC needs a set of system performance requirements as a function of time for the next fifteen years. Capabilities that will drive high volume high performance optical and RF device and system performance include communication within data centers, Mobile Smart Phone Applications, and some IoT applications.

For data center communication, the critical performance metrics include data rate per server unit, energy per bit and latency requirement for server-to-server communications.

For Mobile Smart Phones, the critical requirements include RF operating frequency, maximum data rate, power requirements, number of frequency bands (operating frequencies) and antenna requirements.

The important metrics for IoT applications are: operating frequency, data rate, range, and energy requirements.

7.2. MORE MOORE

OSC will provide input to More Moore on requirements for RF devices and specifically identify gaps in performance targets for FETs and the parasitic capacitance and resistances for gates and S/D contacts.

OSC will provide information to More Moore on circuits/components that may be heterogeneously integrated in 3D with other integrated circuits. OSC will also identify new materials that would most likely be used in 3D integrated applications. This will include RF circuits/devices and optical interconnects that could be integrated at the wafer level or in 3D with CMOS integrated circuits.

7.3. BEYOND CMOS

OSC needs new devices to enable photonic switching and routing and devices that operate at high frequency with low parasitic capacitance and resistance.

OSC will identify material characteristics required to enable solutions to difficult challenges for optical interconnects and RF communication.

For optical interconnects, challenges that could be solved with a new material include: high thermal conductivity heat spreading materials that are electrically insulating, polymer optical waveguide materials with losses less than 0.01 dB/cm, Longer term, devices that could enable photonic logic and routing are being investigated. This would require materials that can switch optical properties of one wavelength when exposed to a different wavelength.

For RF components, materials are needed that reduce gate conductor resistance and materials or structures that reduce specific contact resistance for contact to silicon, SiGe, InP, GaAs, GaN and other III-V materials. These materials are also needed by More Moore to support improvements to silicon and SiGe devices.

7.4. PACKAGING

OSC will identify to the packaging IFT critical capabilities needed to package Photonic and RF components.

To package optical interconnects, the package must accommodate a diversity of materials with different coefficients of thermal expansion, so the package CTE must be matched with that of critical components or the modulus of the package must be low to absorb strain. The temperature of some components including lasers and photodetectors must be controlled within a specified range.

7.5. ENVIRONMENTAL SAFETY, HEALTH AND SUSTAINABILITY

OSC identifies to ESH/S new materials that will be used to manufacture optical interconnects and RF components or be incorporated in them. OSC also identifies materials and product operating effects whose properties need to be assessed through product life.

For optical interconnects and RF devices, the most obvious materials that must be assessed through product life are Ga, As, InP and GaN.

For RF devices, with 5G planning to use mmWave (28–300 GHz) [0.115–1.24 meV], which stimulate vibrational states on O₂ and N₂ at specific frequencies and could cause local heating in focused applications. Potential biological interactions need to be investigated for use in mobile smart phones where focusing antennas will be used.

IEEE Future Networks Beyond 5G Roadmap Team

OSC needs information from the IEEE Future Networks Beyond 5G Roadmap teams on the frequencies and methods to be employed to communicate to mobile phones, autonomous vehicles and other high performance IoT devices.

International Electronics Manufacturing Initiative (iNEMI) Optical Interconnect Team

OSC needs information from iNEMI on performance requirements for optical interconnects in different applications.

8. EMERGING/DISRUPTIVE CONCEPTS AND TECHNOLOGIES

8.1. MMWAVE COMMUNICATION

Although mmWave was first demonstrated in radio communication over 100 years ago, it is now being considered for 5G communication. It is disruptive in that it enables very high-speed data communication; however, there are very serious issues that must be resolved for it to be widely adopted. First of all, it is absorbed by atmospheric gases, so the range is limited to hundreds of meters. Second, mmWave signals are significantly absorbed or blocked by buildings, humans, trees, etc. There are a number of technologies and approaches being developed to minimize the impact of these issues including use of active phased array antennas to focus signals to the receiver and reduce power required for communication and building micro base stations to increase coverage. Active phased array antennas consist of a matrix of antennas that have the phase of each antenna element coordinated to have phases constructively interfere in the target broadcast direction and destructively interfere in other directions. Antennas with more elements are able to focus the broadcast more narrowly, while those with a small matrix of elements will have a larger angular spread of the signal. By focusing the signal to the user, lower energy is used to produce a stronger signal at the users' antenna than if the signal were broadcast in all directions. Although this may extend the range of the base station, micro base stations are being proposed that would be placed in higher density to insure high coverage. Within buildings, in building stations would need to connect with users enter and connect with them as they moved from room to room.

8.2. INTEGRATED SILICON PHOTONICS

A significant barrier to broadly using photonics in “wired” applications is the cost of integrating a wide range of components into a photonic transceiver, assembling it with fiber and installing it for the application. Recently, a few companies have developed integrated silicon photonic “chips” that are “self-aligned” to fibers. These silicon photonic chips have InP lasers, modulators, and multiplexer (MUX) to feed multiple wavelengths into a fiber. They also have a similar chip that has a demodulator (DeMUX) and photodetectors to receive signals from the transmitter. This enables significant cost reduction, increase in data rates and eliminates the tedious assembly of multiple discrete devices. With this milestone, it is expected that increases in data rate will proceed and enable reduction in price per bit in future technologies.

8.3. PHOTONIC SWITCHING AND ROUTING

In large data centers, data is converted from electrical to optical, transmitted over fiber, then converted back to electrical signals at a router where the electrical signals are routed and converted to optical signals and transmitted to the next router. In some cases, this happens up to seven times before the data reaches its destination and these repeated conversions add latency to the communication between servers and other servers or the internet. Work has progressed on hybrid electrical/optical routing where electrical signals establish a route for the optical signals by positioning MEMs devices and later E/O modulators and switches. Thus, once the electrical path has programmed the path, the optical signals move through the routers without conversion to electrical signals. For large data packets, this is very efficient and reduces latency; however, for small packets, this may not be efficient. Research is currently investigating devices for all optical switching and routing to enable all optical routing for small packets of information.

8.4. EMERGING PHENOMENON TO ENABLE NEW PHOTONIC CONTROL

Phenomenon that have the ability to optically amplify, or modulate (wavelengths, polarization or direction) photonic signals or enable photonic memory have the potential to enable lower latency communication in data centers. A few of the new phenomenon are listed to provide examples of research that is emerging.

Plasmonic and dielectric have been demonstrated to rotate polarization of photons in waveguides [96]. This is a major step toward the ability to change the mode of light in waveguides.

A single photon has been demonstrated to initiate 50 ps switching of another wavelength in strongly coupled quantum dot-cavity systems.[97] The ability to activate a photonic switch with a very low trigger level of light could be used to send the routing signal over the same fiber or waveguide as the signal.

A composite photonic crystal on a semiconductor laser enables steering of the emitted laser beam [98].

Optical gain has been demonstrated with an Au plasmonic waveguide embedded in a fluorescent polymer [99].

Packets of light have been shown to persist in a non-linear resonator for use in pulse reshaping, wavelength conversion, and possibly short-term memory [100].

8.5. STRUCTURED LIGHT FOR COMMUNICATIONS

The use of orbital angular momentum (OAM) of light [101, 102], a special class of “structured light”, for data communications has seen great advancement in the optics research and development community. OAM beams of light are also known as vortex beams because of their donut-shaped intensity profiles. Furthermore, the number of 2π phase changes in one full rotation of the helical phase front characterizes the order of the OAM mode. The practical advantages of OAM are twofold. First, the intensity of the OAM beam has circular symmetry which is well suited to the many existing optical elements used in a communication link, like lenses and fiber, as they have a circular cross-section. Second, OAM mode identification can be performed at the receiver even with partial recovery of the beam’s radial intensity information, provided the complete azimuthal information is available. OAM-based mode division multiplexing has been demonstrated in both free-space and fiber and is gaining much interest. It can be combined with WDM and polarization division multiplexing (PDM) to enhance existing transmission capacity. Additionally, several other scenarios (environments) have been identified as potential application grounds for OAM based communication. To name a few:

- a) Underwater communication, e.g., between submarines and/or submersibles.
- b) Communication through air-water interface, e.g., a submarine to an aircraft
- c) In Earth’s atmosphere, e.g., fixed ground terminals to unmanned aerial vehicles (UAV) or airplanes.
- d) Communication to and from ground-station and satellites.
- e) In space, e.g., inter-satellite links.

The major technical hurdles in these applications include combating turbulence, thermal gradients, scattering loss and beam divergence over long distances. Further research is also required to address challenges like inter-modal crosstalk and misalignment at the receiver. Integration of optical elements on chip could also play a major role in reducing the size, weight and power of the transceivers. OAM is in its nascent stage of development but holds much promise for the future.

9. CONCLUSIONS AND RECOMMENDATIONS

9.1. OPTICAL INTERCONNECT CONCLUSIONS

Optical interconnects are used in a number of applications to replace copper interconnects. For data communication in local area networks and data centers, it is to increase communication data rates and reduce power consumption. In automobiles, it is to reduce the weight of communication medium and make automobiles more recyclable; however, as autonomous vehicles are developed higher data rates will be required to provide the navigation and collision avoidance system with input from a wide range of sensors. In aircraft, optical interconnects are immune to electromagnetic interference and reduce the weight when replacing copper interconnects.

For optical interconnects, the introduction of integrated silicon photonic devices has the potential to both reduce cost and increase data rates in fiber communication. This could enable optical communication to be connected in computers and servers and reduce both latency of communication, increase rates of data communication, and reduce the power required to send information. For data centers, this could enable new architectures that would enable faster more efficient communication of data.

A significant cause of latency in data centers is the conversion of optical signals for routing and all optical routing has the potential to reduce latency and reduce energy consumption. Hybrid electrical/optical routing systems have been demonstrated and result in significant reduction in latency for communication of large data sets. Research is making progress on devices that could enable all optical routing in data centers.

9.2. OPTICAL INTERCONNECT RECOMMENDATIONS

In the future, industry should continue to fund research on more energy efficient, compact lasers, modulators and detector/amplifier circuits. They should also evaluate the potential of hybrid E/O and all optical switching and routing capabilities to determine whether they could enable more energy efficient communication within data centers.

With the switch density continuing to increase without any increase in space for connectors, industry should explore new connector technology (e.g., “Break Out” connectors) that would support more servers communicating with the switching matrix.

With photonic modules for in rack applications coming on the market, it is critical that technology be developed that supports interoperability and serviceability to enable high volume use in data centers.

9.3. RF WIRELESS CONCLUSIONS

RF wireless continues to be the primary means of connecting internet of things (IoT) devices to the internet, where IoT includes mobile phones, a wide range of sensors and actuators used in homes, businesses, factories and warehouses, automobiles, and aircraft. With the growth rate of IoT devices connected to the internet and growing number of high data rate applications (e.g. virtual reality, etc.), higher bandwidth will be needed to support the growth in communication between devices and with data centers. Many networks of sensors are specialized and the primary focus is on increasing energy efficiency and connection range but need to be connected to the internet. Clearly, the highest volume of high data rate applications will be smart mobile phones; however, with the development of autonomous vehicles they will need high bandwidth to receive telemetry data on traffic flow, obstructions and to send sensory data and decision analysis to the manufacturer and traffic control functions.

As 5G is developed, mmWave will be implemented to connect micro base stations to the internet and mmWave and massive MIMO will be implemented to connect mobile phones, autonomous vehicles, robots, smart cities and smart homes to the internet. mmWave will require a higher density of base stations and focusing signals to users to connect applications to the internet due to atmospheric absorption and obstruction absorption. Massive MIMO will need to have multiple transmitters communicating with the user, but also find novel approaches of reducing power consumption.

Forecast performance of CMOS, SiGe and III-V devices should meet the requirements of emerging RF applications; however, cost may become challenging for very high frequencies. Key challenges for improvement in the performance of CMOS, SiGe and III-V devices are reduction in resistance of conductors and reduction in contact resistivity.

9.4. RF WIRELESS RECOMMENDATIONS

Support research in novel RF CMOS, SiGe and III-V devices, 2,5D and 3D heterogeneous integration, and their fabrication processes, especially for low resistance conductors and low contact resistances with device elements. Industry should work vigorously with the IEEE Beyond 5G Roadmap and Standards Committees to define in more details technology requirements.

10. ACRONYMS AND ABBREVIATIONS

Term	Definition
1G-4G	First Generation to Fourth Generation
3GPP	Third Generation Partnership Project
5G	Fifth Generation
A&AI	Active & and Available Inventory
AAA	Authentication, Authorization, and Accounting
ACK/NAK	Acknowledgment/Negative Acknowledgment
ADC	Analog to Digital Converter
ADP	Application Domain Profile of IEEE 2413
A-GPS	Assisted GPS
AI	Artificial Intelligence
A2A	All to All
AOC	Active Optical Cables
AMS	Analog/Mixed Signal
API	Application Programming Interface
AR	Augmented Reality
ASIC	Application-Specific Integrated Circuit
B2B	Business to Business
B2C	Business to Consumer
BBU	Base Band Unit
BER	Bit Error Rate
BKC	Best known Configurations
BS	Base Station
BSS	Business Support System
C/U/D/M	Control Plane/User Plane/Data Plane/Management Plane
CAPEX	Capital Expenditure
CBRS	Citizen Band Radio Services
CCIX	Cache Coherent Interconnect for Accelerators
CDMA	Code Division Multiple Access
CEP	Cloud EndPoint
CEQIP	Cryogenic Electronics and Quantum Information Processing
CN	Core Network
CNCF	Cloud Native Computing Foundation

CNFs	Cloud-native Network Functions
CO	Central Office
COBO	Consortium for On Board Optics
COTS	Commercial Off-the-Shelf
CP	Control Plane
CPRI	Common Public Radio Interface
CRD	Custom Resource Descriptors
CU/DU	Centralized Unit/Distributed Unit
CXL	Compute Express Link
DAC	Digital to Analog Converter
D2D	Device to Device
DC	Data Center
DCSA	Data Collection Service and Analytics
DeMUX	Demultiplexer
DevOps	Development and Information Technology Operations
DFFT	Discrete Fourier Transform
DFT-s-OFDM	Discrete Fourier Transform Spread Orthogonal Frequency Division Multiplexing
DL	Downlink
DMD	Digital Micro Mirror Devices
DP	Data Plane
DSA	Domain Specific Application
EAP	Edge Automation Platform
eCPRI	Ethernet Common Public Radio Interface
EEP	Edge EndPoint
eMBB	Enhanced Mobile Broadband
EO	Electronic to Optical
eNB	Evolved Node B
EPC	Evolved Packet Core
ETSI	European Telecommunications Standards Institute
FDD	Frequency-Division Duplex
FET	Field Effect Transistor
FDMA	Frequency Division Multiple Access
FMC	Fixed Mobile Convergence
FPGA	Field-Programmable Gate Array
FTTX	Fiber to X

44 Acronyms and Abbreviations

GHz	Gigahertz
GPU	Graphics Processing Unit
GSMA	GSM (Groupe Speciale Mobile) Association
HA	High Availability
HCI	Hyper-Converged Infrastructure
HEMT	High Electron Mobility Transistor
HIR	Heterogeneous Integration Roadmap
HPC	High Performance Computing
HSS	Home Subscriber Services
ICN	Integrated Cloud Native
IEEE	Institute of Electrical and Electronics Engineers
IETF	Internet Engineering Task Force
IFFT	Inverse Fast Fourier Transform
IMS	IP Multimedia Subsystem
iNEMI	International Electronic Manufacturing Initiative
IOE	Internet of Everything
IoT	Internet of Things
IP	Internet Protocol
IRDS	International Roadmap for Devices and Systems
ISG	Industrial Specification Group
ISP	Internet Service Provider
ITS	Intelligent Transport System
ITU	International Telecommunication Union
ITU-T	ITU Telecommunication Standardization Sector
KPI	Key Performance Indicator
LAA	Licensed Assisted Access
LC	Local Cloud Associated with CO or Edge (Near as Well Far)
LDPC	Low Density Parity Code, Low-Density Parity-Check
LDPE	Licensed Data Payload Encryption
LEL	Living Edge Lab
LFE	Linux Foundation Edge (Akraino Project belongs to LFE)
LPWAN	Low-power WAN
LoRaWAN	Long-range WAN
LNP	Low-Noise Power

LTE	Long-Term Evolution
M2M	Machine to Machine
MAC	Medium Access Control
MANO	Management and Network Orchestration
MBA	Multi-Beam Antenna
MDC	Mobile Data Centers, Micro Data Centers
MEC	Multi Access Edge Computing or Multi-Access Edge Cloud
MEMS	Micro-electro-mechanical Systems
MIMO	Multiple Input, Multiple Output
mMIMO	Massive MIMO
MHEMT	Metamorphic High Electron Mobility Transistor
ML	Machine Learning
MMDC	Mobile MDC
mMTC	Massive Machine-Type Communication
mmWave	Millimeter Wave
MNO	Mobile Network Operator
MR	Merged Reality
MUX	Multiplexer
MVNO	Mobile Virtual Network Operators
NaaS	Network as a Service
NB & SB	North Bound & South Bound
NB-IOT	Narrow Band – Internet of Things
NEP	Network Equipment Operators
NF	Network Function
NFV	Network Function Virtualization
NFVi	Network Function Virtualization Infrastructure
NFVO	NFV Orchestrator
NGC	Next Generation Core
NGCO	Next-Generation Central Office
NGDC	Next Gen Data Centers
NGMN	Next Generation Mobile Networks
NIC	Network Interface Card
NOMA	Non-Orthogonal Multiple Accesses
NPU	Network Processing Unit
NR	New Radio

46 Acronyms and Abbreviations

NS	Network Slicing
NSA	Non-Standalone
NUMA	Non-Uniform Memory Access
NVME	Non-Volatile Memory Express
OAM	Orbital Angular Momentum
OE	Optical To Electronic
OEC	Open Edge Computing
OFDM	Orthogonal Frequency-Division Multiplexing
OMECC	Open Mobile Edge Cloud
ONAP	Open Networking Automation Platform
ONF	Open Networking Foundation
OOM	ONAP Operation Manager
OpenNESS	Open Network Edge Services Software
OPEX	Operational Expenditure
OPNFV	Open Platform Network Virtualization
OSM	Order and Service Management
OSS	Operational Support System
OTA	Over The Air
OTT	Over the Top
PAM	Pulse Amplitude Modulation
PCB	Printed Circuit Board
PDM	Polarization Division Multiplexing
PGW	Packet Gateway
PHEMT	Pseudomorphic High Electron Mobility Transistor
PHY	Physical Layer
PoC	Proof of Concept
PPS	Packets Per Second
PTP	Point-To-Point
QEMU	Quick Emulator
QKD	Quantum Key Distribution
QoE	Quality of Experience
QoS	Quality of Service
RA	Reference Architecture
RAN	Radio Access Network
RE	Range Extension

RF	Reference Framework, Radio Frequency
RI	Reference Implementation
RI-EAP	Reference Implementation of EAP
RII-EAP	Reference Intelligent Infrastructure for EAP (IEEE 1934.EAP)
RM	Reference Models
RNIS	Radio Network Information Service
ROADM	Reconfigurable Optical Add Drop Multiplexer
RRH	Remote Radio Head
RRH	Remote Radio Head
RS-EAP	Reference Stack for EAP (IEEE 1934.EAP)
RSRP	Reference Signal Received Power
RTT	Real-Time Technology
RU	Radio Unit
RWM	Reference Workload Models (IEEE 1934.EAP)
SDN	Software Defined Network
SDO	Standards Developing Organization or Standards Development Organization
SFQ	Single Flux Quantum
SIGFOX	A wireless interface, cellular style, long range, low power, low data rate form of wireless communications developed to provide wireless connectivity for devices like remote sensors, actuators and other M2M and IoT devices
SIM	Subscriber Identification Module
SLA	Service Level Agreements
SOA	Semiconductor Optical Amplifier
SON	Self-Optimizing Network
SP	Service Provider
SUT	System Under Test
TBPS	Terabytes per Second
TDD	Time-Division Duplex
TDMA	Time Division Multiple Access
THz	Terahertz
TIP	Telecommunication Infrastructure Platform
TP	Technical Profile of IEEE 2413
TSDSI	Telecommunications Standards Development Society India
TTI	Transmission Time Interval
TUG	Telecom Users Group

48 Acronyms and Abbreviations

Tx/Rx	Transmit and Receive
UAV	Unmanned Aerial Vehicles
uCPE	Universal Customer Premise Equipment
UE	User Equipment
UL	Uplink
UP	User Plane
URLLC	Ultra-Reliability Low-Latency Connection
V2I	Vehicle to Infrastructure
V2V	Vehicle to Vehicle
vBBU	Virtual Base Band Unit
vBNG	vBroadband Virtual Broadband Network Gateway
VCSEL	Vertical Cavity Surface Emitting Laser
vEPC	Virtual Evolved Packet Core
VNF	Virtual Network Function
VR	Virtual Reality
WAN	Wireless Area Network
WDM	Wavelength Division Multiplexing
WG	Working Group
WRC	World Radiocommunication Conferences

11. REFERENCES

- [1] White Paper – Cisco Global Cloud Index: 2014–2019: https://www.cisco.com/c/dam/m/en_us/service-provider/ciscoknowledgenetwork/files/547_11_10-15-DocumentsCisco_GCI_Deck_2014-2019_for_CKN_10NOV2015_.pdf
- [2] S. M. R. Motaghianezam, I. Lyubomirsky, H. Daghighian, C. Kocot; et.al. “180 Gbps PAM4 VCSEL transmission over 300m wideband OM4 fibre.” 2016 Optical Fiber Communications Conference and Exhibition (OFC). Anaheim, CA, USA, 20-24 March 2016.
- [3] N. N. Ledentsov, V.A. Shchukin, V.P. Kalosha, N. Ledentsov Jr, L. Chorchos, J. P. Turkiewicz, U. Hecht, P. Kurth, F. Gerfers, J. Lavrencik, S. Varughese, and S. E. Ralph. “Optical Interconnects Using Single-Mode and Multi-Mode VCSEL and Multi-Mode Fiber.” Optical Fiber Communication Conference (OFC) 2020, OSA Technical Digest (Optical Society of America, 2020), paper M3D.1.
- [4] N. Ledentsov, L. Chorchos, V. A. Shchukin, V. P. Kalosha, J. P. Turkiewicz, and N. N. Ledentsov, "Development of VCSELs and VCSEL-based Links for Data Communication beyond 50Gb/s," Optical Fiber Communication Conference (OFC) 2020, OSA Technical Digest (Optical Society of America, 2020), paper M2A.3.
- [5] G. Wang, et al. “Your Data Center is a Router: The case for Reconfigurable Optical Circuit Switched Paths.” Proc. ACM Hotnets VIII (New York City, NY, USA) (2009).
- [6] N. Farington. “Helios: A Hybrid Electrical/Optical Switch Architecture for Modular Data Centers” Proceedings of the 2010 SIGCOMM Conference, New Delhi, India.
- [7] G. Porter, et al. “Integrating microsecond Circuit Switching into the Data Center.” Proceedings of the 2013 ACM SIGCOMM’13, Hong Kong, China, pp. 447–458.
- [8] M. Ghobadi, et al. “ProjecToR: Agile Reconfigurable Data Center Interconnect.” Proceedings of the 2016 ACM SIGCOMM Conference, Florianopolis, Brazil.
- [9] Q. Cheng, et.al. “Scalable, Low-Energy Hybrid Photonic Space Switch.” J. of Lightwave Technology **31**, pp. 3077–3084 (2013).
- [10] B.G. Lee, et al. “Monolithic Silicon Integration of Scaled Photonic Switch Fabrics, Logic, and Device Driver Circuits.” J. of Lightwave Technology **32**, pp. 743–751 (2014).
- [11] D. Nikolova, et al. “Scaling Silicon Photonic Switch Fabrics for Data Center Interconnection Networks.” Optics Express
- [12] J.S. Pelc, et al. “Picosecond all Optical Switching in Hydrogenated Amorphous Silicon Microring Resonators.” Optics Express **22**, pp. 3797–3810 (2014).
- [13] S. Pitris, G. Dabos, C. Mitsolidou, T. Alexoudi, P. De Heyn, J. Van Campenhout, R. Broeke, G. T. Kanellos, and N. Pleros. “Silicon photonic 8×8 cyclic Arrayed Waveguide Grating Router for O-band on-chip communication.” Optics Express **26**, pp 6276-6284 (2018).
- [14] J. Lavrencik, S. Varughese, V. A. Thomas, G. Landry, Y. Sun, R. Shubochkin, K. Balemarthy, J. Tatum, and S. E. Ralph. “ $4 \lambda \times 100$ Gbps VCSEL PAM-4 Transmission over 105m of Wide Band Multimode Fiber.” OSA Technical Digest paper Tu2B.6, paper Tu2B.6, Optical Society of America, March 2017.
- [15] A. G. Fowler, M.Mariantoni, J.M.Martinis, & A.N. Cleland, “Surface codes: towards practical large-scale quantum computation.” *Phys. Rev. A* **86**, 032324 (2012).
- [16] M. Reiher, N. Wiebe, K.M. Svore, D. Wecker, & M.Troyer, “Elucidating reaction mechanisms on quantum computers.” *Proc. Natl Acad. Sci. USA* **114**, 7555–7560 (2017).
- [17] C. Gidney, & M.Ekera. How to factor 2048 bit RSA integers in 8 hours using 20 million noisy qubits. *Quantum* **5**, pp.433 (2021).
- [18] D. Awschalom, K. K. Berggren, H. Bernien, S. Bhave, et al. “Development of Quantum Interconnects (QuICs) for Next-Generation Information Technologies.” *PRX Quantum* **2**, pp. 017002 (2021)
- [19] F. Lecocq, F. Quinlan, K. Cicak, J. Aumentado, S. A. Diddams & J. D. Teufel. “Control and readout of a superconducting qubit using a photonic link.” *Nature*, Vol 591 |pp. 017002-1-21, 25 March 2021.
- [20] M. Mirhosseini, A. Sipahigil, M. Kalae, and O. Painter. “Quantum transduction of optical photons from a superconducting qubit.” *Nature* **588**, pages599–603 (2020).
- [21] A. Youssefi, I. Shomroni, Y.J. Joshi, N.R. Bernier, et.al. “A cryogenic electro-optic interconnect for superconducting devices.” *Nature Electronics* **4**, pages326–332 (2021).

50 References

- [22] A. Gold, J.P Paquette, A. Stockklauser, M.J. Reagor, et al. “Entanglement across separate silicon dies in a modular superconducting qubit device.” *npj Quantum Information* 7, 142 (2021).[14]Principles of LED Light Communication Toward Networked Li-Fi. S. Dimitrov and H. Haas. Cambridge University Press, Cambridge CB2 8BS, United Kingdom, (2015). ISBN: [9781107049420](https://doi.org/10.1017/9781107049420).
- [23] A. Gomez, K. Shi, C. Quintana, M. Sato, G. Faulkner, B. C. Thomsen, and D. O’Brien. “Beyond 100-Gb/s Indoor Wide Field-of-View Optical Wireless Communications”. *IEEE Photonics Tech. Lett.* 27, pp. 367–370, (2015). DOI: [10.1109/LPT.2014.2374995](https://doi.org/10.1109/LPT.2014.2374995).
- [24] C. Lee, M. Sufyan Islim, S. Videv, A. Sparks, B. Shah, P. Rudy, M. McLaurin, H. Haas, and J. Raring. “Advanced LiFi technology: Laser light.” *SPIE Proceedings Volume 11302, Light-Emitting Devices, Materials, and Applications XXIV*; 1130213 (2020). <https://doi.org/10.1117/12.2537420>.
- [25] <https://spectrum.ieee.org/video/telecom/wireless/5g-bytes-full-duplex-explained>
- [26] I.M. Yi, N. Miura, H. Fukuyama, H. Nosaka. “A 15.1 mW 6GS/s flash ADC with Selectively Activated 8x time-domain interpolation.” *IEEE Asian Solid State Circuits Conference*, Nov. 5-7, 2018, Tinian Taiwan. Pp. 239-242.
- [27] W.-b. Abbas, F. Gomez-Cuba, and M. Zorzi. “Millimeter wave receiver efficiency: A comprehensive comparison of beamforming schemes with low resolution ADCs.” *arXiv preprint arXiv:1607.03725* (2016). <https://arxiv.org/abs/160703725>
- [28] A. Alkhateeb, et al. “MIMO precoding and combining solutions for millimeter-wave systems.” *IEEE Communications Magazine* 52.12 (2014): 122–131.
- [29] C. Risi, D. Persson, and E. G. Larsson. “Massive MIMO with 1-bit ADC.” *arXiv preprint arXiv:1404.7736* (2014). <https://arxiv.org/abs/1404.7736>
- [30] S. Kutty and D. Sen. “Beamforming for millimeter wave communications: An inclusive survey.” *IEEE Communications Surveys & Tutorials* 18.2 (2016): 949–973.
- [31] Y. Huo, X. Dong and W. Xu, “5G Cellular User Equipment: From Theory to Practical Hardware Design,” in *IEEE Access*, vol. 5, pp. 13992–14010, 2017. DOI: [10.1109/JPROC.2012.2207649](https://doi.org/10.1109/JPROC.2012.2207649)
- [32] J.G. Andrews, et al. “Modeling and analyzing millimeter wave cellular systems.” *IEEE Transactions on Communications* 65.1 (2017): 403–430.
- [33] E. Chan. “Wireless Optical Links for Airplane Applications”, *Photonics Society Summer Topical Meeting Series, IEEE 09 Jul – 11 Jul 2012 Seattle, WA, USA*, pp. 76–77, (2012). DOI: [10.1109/PHOSST.2012.6280709](https://doi.org/10.1109/PHOSST.2012.6280709).
- [34] D. Marinos, C. Aidinis, N. Schmitt, J. Klaue, J. Schalk, T. Pistner, P. Kouros. “Wireless optical OFDM implementation for aircraft cabin communication links”. *5th International Symposium on Wireless Pervasive Computing (ISWPC)*, (2010). DOI: [10.1109/ISWPC.2010.5483801](https://doi.org/10.1109/ISWPC.2010.5483801).
- [35] E. Chan, D. Koshinz, W. Krug, and H. Hager. “Wireless optical links for avionics applications”. *Proc. SPIE 8026, Photonic Applications for Aerospace, Transportation, and Harsh Environment II*, 80260M (2011). DOI: [10.1117/12.886858](https://doi.org/10.1117/12.886858).
- [36] H. Savci, A. Sula, Z. Wang, N. S. Dogan, and E. Arvas. MICS transceivers: regulatory standards and applications [medical implant communications service]. In *Proceedings of IEEE SoutheastCon 2005*, pages 179–182, April 2005.
- [37] G. Yeap et al., TSMC, “5nm CMOS Production Technology Platform Featuring Full-Fledged EUV and High-Mobility Channel FinFETs with Densest 0.021 μm^2 SRAM Cells for Mobile SoC and High-Performance Computing Applications,” *IEDM 2019 Paper #36.7*
- [38] S.P. Voinigescu, S. Shopov, J. Bateman, H. Farooq, J. Hoffman, and K. Vasilakopoulos. “Silicon millimeter-wave. Terahertz, and high-speed fiber-optic device and benchmark circuit scaling through the 2030 ITRS horizon.” *Proceedings of the IEEE* 105, pp. 1087-1104, 2017. DOI: [10.1109/JPROC.2017.2672721](https://doi.org/10.1109/JPROC.2017.2672721)
- [39] K. Hijioka, J. Kawahara, M. Narihiro, I. Kume, A. Tanabe, H. Nagase, H. Yamamoto, N. Inoue, T. Takeuchi, T. Onodera, S. Saito, N. Furutake, and Y. Hayashi.” Rf performance upgrading of low-power 40nm-node CMOS devices by extremely low-resistance partially-thickened local (PTL)-interconnects.” *Proceedings of the 2009 IEEE international electron devices meeting (IEDM)* pp 887-889.
- [40] C. Auth, et al. “A 10nm High Performance and Low-Power CMOS Technology Featuring 3rd Generation FinFET Transistors, Self-Aligned Quad Patterning, Contact over Active Gate and Cobalt Local Interconnects.” *Proceedings of the 2017 IEEE International Electron Devices Meeting (IEDM)*, 29.1.

- [41] M. Schröter, T. Rosenbaum, P. Chevalier, B. Heinemann, S. Voinigescu, E. Preisler, J. Boeck, A. Mukherjee, “SiGe HBT technology: Future trends and TCAD based roadmap”, Proc. of the IEEE, Vol. 105, No. 6, pp. 1068–1086, 2017. DOI: [10.1109/JPROC.2015.2500024](https://doi.org/10.1109/JPROC.2015.2500024)
- [42] B. Heinemann et al., “SiGe HBT with fT/fMAX of 505 GHz/720 GHz”, IEDM Tech. Digest, 2016.
- [43] P. Chevalier, M. Schröter, C.R. Bolognesi, V. d’Alessandro, M. Alexandrova, J. Böck, R. Flückiger, S. Fregonese, B. Heinemann, C. Jungemann, R. Lövblom, C. Maneux, O. Ostinelli, A. Pawlak, N. Rinaldi, H. Rücker, G. Wedel, and T. Zimmer, “Si/SiGe:C and InP/GaAsSb Heterojunction Bipolar Transistors for THz Applications”, Proc. of the IEEE, Vol. 105, No. 6, pp. 1035–1050, 2017. DOI: [10.1109/JPROC.2017.2669087](https://doi.org/10.1109/JPROC.2017.2669087)
- [44] M. Urteaga, Z. Griffith, M. Seo, J. Hacker, M. Rodwell, “InP HBT technologies for THz integrated circuits”, Proc. of the IEEE, Vol. 105, No. 6, pp. 1051–1067, 2017.
- [45] N. Ojaroudiparchin, M. Shen, S. Zhang, and G. Frølund Pedersen. “A Switchable 3D-Coverage Phased Array Antenna Package for 5G Mobile Terminals.” *IEEE Antennas and Wireless Propagation Letters*, 15, pp. 1747–1750. (2016) DOI: [10.1109/LAWP.2016.2532607](https://doi.org/10.1109/LAWP.2016.2532607)
- [46] Y.-L. Ban, C. LI, C.-Y.-Desmond Sim, G. Wu, and K.-L. WONG. “4G/5G Multiple Antennas for Future Multi-47] S. S. Dhillon et al, "The 2017 terahertz science and technology roadmap", J. Phys. D: Appl. Phys., Vol. 50, 49 pp, 2017.
- [48] N. Rinaldi and M. Schröter, Silicon-Germanium Heterojunction Bipolar Transistors for Mm-wave Systems Technology, Modeling and Circuit Applications, River Publ., The Netherlands, 2018.
- [49] X. Mei, W. Yoshida, ... W. Deal, "First Demonstration of Amplification at 1 THz Using 25-nm InP High Electron Mobility Transistor Process", IEEE Electron Dev. Lett., Vol. 36, No. 4, pp. 327-329, 2015.
- [50] S. P. Voinigescu, S. Shopov, ... K. Vasilakopoulos, "Silicon Millimeter-Wave, Terahertz, and High-Speed Fiber-Optic Device and Benchmark Circuit Scaling Through the 2030 ITRS Horizon," Proc. of the IEEE, vol. 105, no. 6, pp. 1087-1104, 2017.
- [51] W. Deal, X. B. Mei, K. M. K. H. Leong, V. Radisic, S. Sarkozy, and Richard Lai. “THz Monolithic Integrated Circuits Using InP High Electron Mobility Transistors.”
- [52] M. Urteaga, Z. Griffith, M. Seo, J. Hacker, and M. J. W. Rodwell.” InP HBT Technologies for THz Integrated Circuits.” *Proceedings of the IEEE* 105, pp. 1051 - 1067 (2017).
- [53] N. Ledentsov, L. Chorchos, O. Makarov, J.-R. Kropp, V. A. Shchukin, V. P. Kalosha, J. P. Turkiewicz, N. Cherkashin, and N. N. Ledentsov "Quantum-dot oxide-confined 850-nm VCSELs with extreme temperature stability operating at 25 Gbit/s up to 180°C", Proc. SPIE 11300, Vertical-Cavity Surface-Emitting Lasers XXIV, 113000H (24 February 2020); <https://doi.org/10.1117/12.2543244>
- [54] H. Huang, J. Duan, B. Dong, J. Norman, D. Jung, J. E. Bowers, and F. Grillot. “Epitaxial quantum dot lasers on silicon with high thermal stability and strong resistance to optical feedback.” *Applied Physics Letters Photonics* **5**, 016103 (2020); <https://doi.org/10.1063/1.5120029>
- [55] B. Ellis, M. Mayer, G. Shambat, T. Sarmiento, E. Haller, J. S. Harris, and J. Vuckovic. “Ultralow-threshold electrically pumped quantum-dot photonic-crystal nanocavity laser”. *Nature Photonics* **5**, pp. 297–300 (2011). DOI: [10.1038/nphoton.2011.51](https://doi.org/10.1038/nphoton.2011.51).
- [56] G. Shambat, B. Ellis, A. Majumdar, J. Petykiewicz, M. A. Mayer, T. Sarmiento, J. Harris, E. E. Haller and J. Vuckovic. “Ultrafast direct modulation of a single-mode photonic crystal nanocavity light-emitting diode”. *Nature Communications* **2**, 593 (2011). DOI: [10.1038/ncomms1543](https://doi.org/10.1038/ncomms1543).
- [57] L. Feng, Z. Jing Wong, R.-M. Ma, Y. Wang, and X. Zhang. “Single-mode laser by parity-time symmetry breaking.” *Science* **346**, pp. 972-975, (2014). DOI: [10.1126/science.1258479](https://doi.org/10.1126/science.1258479).
- [58] W. M. Green, M. J. Rooks, L. Sekaric, and Y. A. Vlasov. “Ultra-compact, low RF power, 10 Gb/s silicon Mach-Zehnder modulator”. *Optics Express* **15**, pp. 17106–17113, (2007). DOI: [10.1364/OE.15.017106](https://doi.org/10.1364/OE.15.017106).
- [59] Q. Xu, B. Schmidt, S. Pradhan, and M. Lipson. “Micrometre-scale silicon electro-optic modulator”. *Nature* **435**(7040), 325–327 (2005). DOI: <https://doi.org/10.1038/nature03569>
- [60] T. Tanabe, K. Nishiguchi, E. Kuramochi, and M. Notomi. “Low power and fast electro-optic silicon modulator with lateral p-i-n embedded photonic crystal nanocavity”. *Opt. Express* **17**, pp. 22505–22513, (2009). DOI: [10.1364/OE.17.022505](https://doi.org/10.1364/OE.17.022505).

52 References

- [61] P. Dong, S. Liao, D. Feng, H. Liang, D. Zheng, R. Shafiiha, C.-C. Kung, W. Qian, G. Li, X. Zheng, A. V. Krishnamoorthy, and M. Asghari. “Low Vpp, ultralow-energy, compact, high-speed silicon electro-optic modulator”. *Optics Express* **17**, pp. 22484–22490, (2009). DOI: [10.1364/OE.17.022484](https://doi.org/10.1364/OE.17.022484).
- [62] G. Shambat, B. Ellis, M. Mayer, A. Majumdar, E. Haller, and J. Vuckovic. “Ultra-low power fiber-coupled gallium arsenide photonic crystal cavity electro-optic modulator”. *Optics Express*, **19**, pp. 7530–7536 (2011). DOI: [10.1364/OE.19.007530](https://doi.org/10.1364/OE.19.007530).
- [63] D.A.B. Miller. “Energy consumption in optical modulators for interconnects”. *Optics Express*. **20**, A293 (2012). DOI: [10.1364/OE.20.00A293](https://doi.org/10.1364/OE.20.00A293).
- [64] D. Feng, W. Qian, H. Liang, C.-C. Kung, Z. Zhou, Z. Li, J. S. Levy, R. Shafiiha, J. Fong, B. J. Luff, and M. Asghari. “High-Speed GeSi Electroabsorption Modulator on the SOI Waveguide Platform”. *IEEE J. of Selected Topics in Quantum Electronics* **19**, pp. 64-73, (2013). DOI: [10.1364/OE.20.022224](https://doi.org/10.1364/OE.20.022224).
- [65] C. Haffner, W. Heni, Y. Fedoryshyn, J. Niegemann, A. Melikyan, D. L. Elder, B. Baeuerle, Y. Salamin, A. Josten, U. Koch, C. Hoessbacher, F. Ducry, L. Juchli, A. Emboras, D. Hillerkuss, M. Kohl, L. R. Dalton, C. Hafner and J. Leuthold. “All-plasmonic Mach–Zehnder modulator enabling optical high-speed communication at the microscale”. *Nature Photonics* **9**, pp. 525–528 (2015). DOI: [10.1038/nphoton.2015.127](https://doi.org/10.1038/nphoton.2015.127).
- [66] C. Haffner, D. Chelladurai, Y. Fedoryshyn, A. Jostyn, B. Baeuele, et.al. “Low Plasmon-assisted electro-optic modulator.” *Nature* **556**, pp. 483-486 (2018), DOI: 0.1038/s41586-018-0031-4.
- [67] W. Heni, Y. Fedoryshyn, B. Baeuele, A. Jostyn, C.B. Hoesbbacker, et al. “Plasmonic IQ modulators with attojoule per bit energy consumption.” *Nature Comm.* **10**, 1694 1-8 (2019). DOI: [10.1038/s41467-019-09724-7](https://doi.org/10.1038/s41467-019-09724-7)
- [68] Y.-H. Kuo, Y. K. Lee, Y. Ge, S. Ren, J. E. Roth, T. I. Kamins, D. A. B. Miller, and J. S. Harris. “Strong quantum-confined Stark effect in germanium quantum-well structures on silicon”. *Nature* **437**, pp. 1334–1336, (2005). DOI: [10.1038/nature04204](https://doi.org/10.1038/nature04204).
- [69] P. Chaisakul, D. Marris-Morini, M.-S. Rouifed, G. Isella, D. Chrastina, J. Frigerio, X. Le Roux, S. Edmond, J.-R. Coudevyille, and L. Vivien. “23 GHz Ge/SiGe multiple quantum well electroabsorption modulator”. *Optics Express* **20**, p. 3219, (2012). DOI: [10.1364/OE.20.003219](https://doi.org/10.1364/OE.20.003219).
- [70] J. Bleuse, G. Bastard, and P. Voisin. “Electric-Field-Induced Localization and Oscillatory Electro-optical Properties of Semiconductor Superlattices.” *Phys. Rev. Lett.* **60**, pp. 220-224 (1988).
- [71] E. E. Mendez, F. Agulló-Rueda, and J. M. Hong. “Stark Localization in GaAs-GaAlAs Superlattices under an Electric Field.” *Phys. Rev. Lett.* **60**, 2426 (1988).
- [72] P. Voisin, J. Bleuse, C. Bouche, S. Gaillard, C. Alibert, and A. Regreny. “Observation of the Wannier-Stark Quantization in a Semiconductor Superlattice.” *Phys. Rev. Lett.* **61**, 1639 (1988).
- [73] J.E. Bigan, J.C. Harmand, M. Allovon, M. Carre, A. Carencio, and P. Voisin. “Wannier-Stark Localization in a 1.55 μm InGaAs/InAlAs Superlattice Waveguide Modulator Structure.” *IEEE Photonics Technology Letters*, **3**, pp. 1107–1109 (1991).
- [74] C. Augusto, L. Forester, “Novel Si–Ge–C superlattices and their applications”, *Solid-State Electronics*, Vol. 110, August 2015, Pages 1–9, Selected papers from the 7th International SiGe Technology and Device Meeting (ISTDM 2014), DOI: [10.1016/j.sse.2015.01.019](https://doi.org/10.1016/j.sse.2015.01.019).
- [75] S. A. Maier, M. L. Brongersma, P. G. Kik, S. Meltzer, A. A. G. Requicha, and H. A. Atwater. “Plasmonics—A Route to Nanoscale Optical Devices”. *Adv. Mater.*, **13**, pp. 1501–1505, (2001). DOI: [10.1002/adma.200390134](https://doi.org/10.1002/adma.200390134).
- [76] G. Veronis, Z. Yu, S. E. Kocabas, D. A. B. Miller, M. L. Brongersma, and S. Fan. “Metal-dielectric-metal plasmonic waveguide devices for manipulating light at the nanoscale”. *Chinese Optics Letters*, **7**, pp. 302–308, (2009). PDF: <http://ee.stanford.edu/~dabm//373.pdf>.
- [77] D. A. Svintsov, A. V. Arsenin, and D. Yu. Fedyanin. “Full loss compensation in hybrid plasmonic waveguides under electrical pumping.” *Optics Express* **23**, p. 19359, (2015).
- [78] Z. Yu, G. Veronis, S. Fan, and M. L. Brongersma. “Design of midinfrared photodetectors enhanced by surface plasmons on grating structures”. *Applied Physics Letters* **89**, p. 151116, (2006). DOI: [10.1063/1.2360896](https://doi.org/10.1063/1.2360896).
- [79] Z. Yu, G. Veronis, S. Fan, and M. L. Brongersma. “Gain-induced switching in metal-dielectric-metal plasmonic waveguides.” *Applied Physics Letters* **92**, p. 041117, (2008).
- [80] J. A. Schuller, E. S. Barnard, W. Cai, Y C. Jun, J. S. White and M. L. Brongersma. “Plasmonics for extreme light concentration and manipulation”. *Nature Materials* **9**, pp. 193–204, (2010). DOI: [10.1038/nmat2630](https://doi.org/10.1038/nmat2630).

- [81] W. Cai, J. S. White, and M. L. Brongersma. “Compact, High-Speed and Power-Efficient Electrooptic Plasmonic Modulators”. *Nano Lett.* **9**, pp. 4403–4411, 2009. DOI: [10.1021/nl902701b](https://doi.org/10.1021/nl902701b).
- [82] S. Papaioannou, D. Kalavrouziotis, K. Vyrsokinos, J.-C. Weeber, K. Hassan, L. Markey, A. Dereux, A. Kumar, S. I. Bozhevolnyi, M. Baus, T. Tekin, D. Apostolopoulos, H. Avramopoulos, and N. Pleros. “Active plasmonics in WDM traffic switching applications”. *Nature Scientific Reports* **2**, p. 652, (2012). DOI: [10.1038/srep00652](https://doi.org/10.1038/srep00652).
- [83] C. Haffner, W. Heni, Y. Fedoryshyn, J. Niegemann, A. Melikyan, D. L. Elder, B. Baeuerle, Y. Salamin, A. Josten, U. Koch, C. Hoessbacher, F. Ducry, L. Juchli, A. Emboras, D. Hillerkuss, M. Kohl, L. R. Dalton, C. Hafner, and J. Leuthold. “All-plasmonic Mach–Zehnder modulator enabling optical high-speed communication at the microscale”. *Nature Photonics* **9**, pp. 525–529, (2015). DOI: [10.1038/nphoton.2015.127](https://doi.org/10.1038/nphoton.2015.127).
- [84] B. Baum, H. Alaeian, and J. Dionne. “A parity-time symmetric coherent plasmonic absorber-amplifier”. *J. Appl. Phys.* **117**, p. 063106, (2015). DOI: [10.1063/1.4907871](https://doi.org/10.1063/1.4907871).
- [85] V. Liu, D. A. B. Miller and S. Fan. “Application of computational electromagnetics for nanophotonics design and discovery”. *Proceedings of the IEEE*, vol. 101, no. 2, pp. 484–493 (2013). DOI: [10.1109/JPROC.2012.2207649](https://doi.org/10.1109/JPROC.2012.2207649).
- [86] A.Y. Piggott, J. Lu, K.G. Lagoudakis, J. Petykiewicz, T.M. Babinec, and J. Juckovic. “Inverse design and demonstration of a compact and broadband on-chip wavelength demultiplexer.” *Nature Photonics* **9**, pp.374-377 (2015). DOI: [10.1038/NPHOTON.2015.69](https://doi.org/10.1038/NPHOTON.2015.69)
- [87] S. Jahani, S. Kim, J. Atkinson, J.C. Wirth, F. Kalhor, et al. “Controlling evanescent waves using silicon photonic all-dielectric metamaterials for dense integration.” *Nature Comm.* **9**, 1893 1-9 (2018). DOI: [10.1038/s41467-018-04276-8](https://doi.org/10.1038/s41467-018-04276-8)
- [88] W. Song, R. Gatdula, S. Abbaslou, M. Lu, A. Stein, et al. “High density waveguide superlattices with low crosstalk.” *Nature Comm.* **6**, pp. 7027 1-9 (2015). DOI: [10.1038/ncomms8027](https://doi.org/10.1038/ncomms8027)
- [89] D.A. Aranzo, S. Nanot, E.J.C Dias, I. Epstein, C. Peng, et al. “Probing the ultimate plasmon confinement limit with a van der Waals heterostructure.” *Science* **360**, pp. 291-295 (2018). DOI: [10.1126/science.aar8438](https://doi.org/10.1126/science.aar8438)
- [90] M.N. Gjerding, M. Pandey and K.S. Thygesen. “Nature Comm. **8**, pp. 15133 1-8. DOI: [10.1038/ncomms15133](https://doi.org/10.1038/ncomms15133)
- [91] V. Van, T. A. Ibrahim, K. Ritter, P. P. Absil, F. G. Johnson, R. Grover, J. Goldhar, and P.-T. Ho. “All-optical nonlinear switching in GaAs–AlGaAs microring resonators”. *IEEE Photon. Technol. Lett.* **14**, pp. 74–76 (2002). DOI: [10.1109/68.974166](https://doi.org/10.1109/68.974166).
- [92] T. A. Ibrahim, W. Cao, Y. Kim, J. Li, J. Goldhar, P.-T. Ho, and C. H. Lee. ”All-optical switching in a laterally coupled microring resonator by carrier injection”. *IEEE Photon. Technol. Lett.* **15**, pp. 36–38, (2003). DOI: [10.1109/LPT.2002.805877](https://doi.org/10.1109/LPT.2002.805877).
- [93] V. R. Almeida, C. A. Barrios, R. R. Panepucci, and M. Lipson. “All-optical control of light on a silicon chip”. *Nature* **431**, pp. 1081–1084, (2004). DOI: <http://dx.doi.org/10.1038/nature02921>.
- [94] Y. A. Zaghloul, A. R. M. Zaghloul, and A. Adibi. “Passive all-optical polarization switch, binary logic gates, and digital processor”. *Optics Express* **19**, p. 20335, 2011. DOI: [10.1364/OE.19.020332](https://doi.org/10.1364/OE.19.020332).
- [95] J. H. Kim, Y. I. Kim, Y. T. Byun, Y. M. Jhon, S. Lee, S. H. Kim and D. H. Woo. “Optical-Amplifier-Based Devices and Their Applications”. *J. of the Korean Physical Society* **45**, pp. 1158–1161, 2004. PDF: <http://optiwave.com/wp-content/uploads/2014/10/xor-based-soa.pdf>.
- [96] Z. Li, et al. “Controlling propagation and Coupling of Waveguide Modes Using Phase-Gradient Metasurfaces.” *Nature Nanotechnology* **12**, pp. 675-683 (2017).
- [97] T. Holtz, et al. “Ultrafast All-Optical Switching by Single Photons.” *Nature Photonics* **6**, pp. 605–609 (2012).
- [98] Y. Kurosaka, et al. “On Chip Beam-Steering Photonic-Crystal Lasers.” *Nature Photonics* **4**, pp. 447–450 (2010).
- [99] M. Gather, K. Meerholz, N. Danz, and K. Leosson. “Net Optical Gain in a Plasmonic Waveguide Embedded in a Fluorescent Polymer.” *Nature Photonics* **4**, pp. 457–461 (2010).
- [100] F. Leo, et al. “Temporal Cavity Solitons in One-dimensional Kerr Media as Bits in An All-optical Buffer.” *Nature Photonics* **4**, pp. 471–476 (2010).
- [101] A. E. Willner, K. Pang, H. Song, K. Zou, and H. Zhou , "Orbital angular momentum of light for communications", *Applied Physics Reviews* **8**, 041312 (2021).
- [102] A. E. Willner, "OAM Light for Communications," *Optics & Photonics News* **32**(6), 34-41 (2021)